



Specifications for Appliance Flare Room Definer 60H

Factor	NG	LPG
Burner Type	35,55,35	35,55,35
Orifice	500,800,500	160,160,160
BTU Max.	50000	41000
BTU min.	28000	20000
Kw/h	14.6k	12k
Chimney DIA.	5X8	5X8
Manifold Pressure[w.c]	3.3	8
Efficiency rate	77	80

Glass Size Length\Width	1450 X620 mm	57" 1/16 X 24" 7/16'
Appliance Weigh	190Kg	418lb

Appliance Location

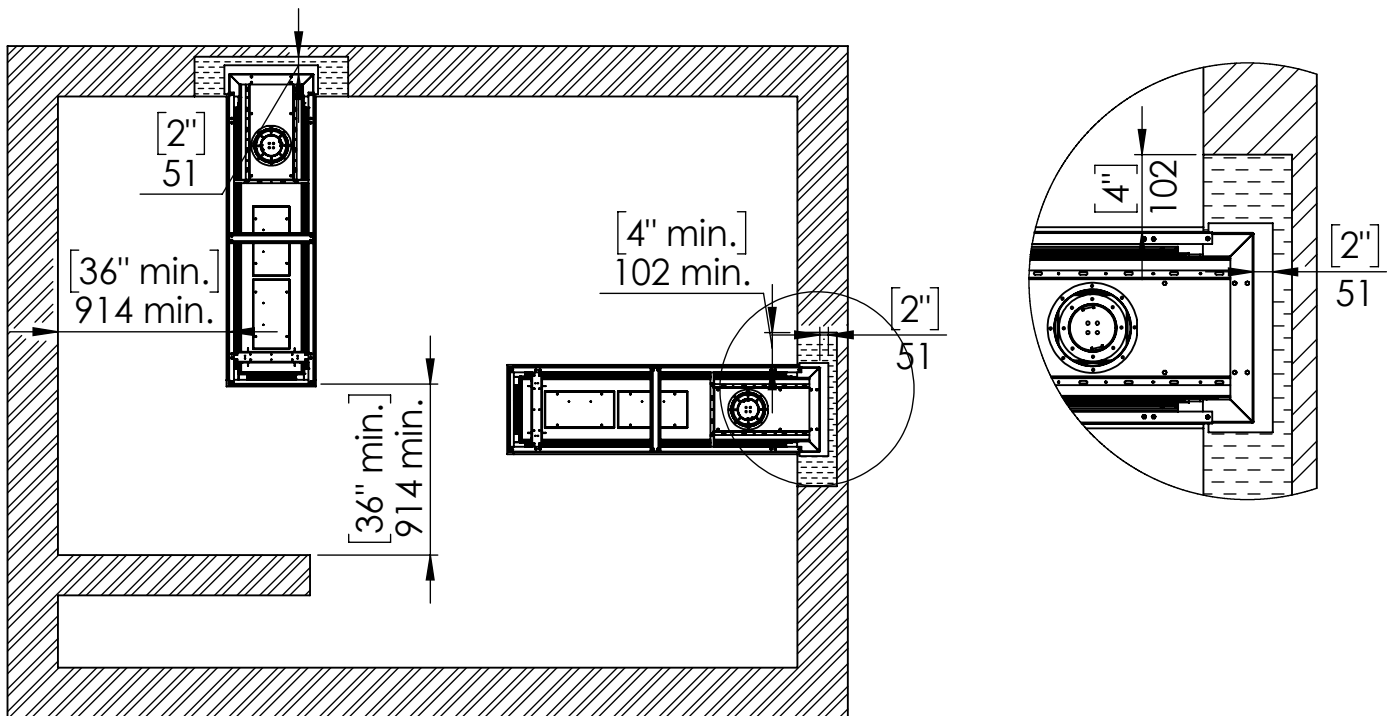

 Combustible Materials
 Non Combustible Materials



Flare Room Definer 60H

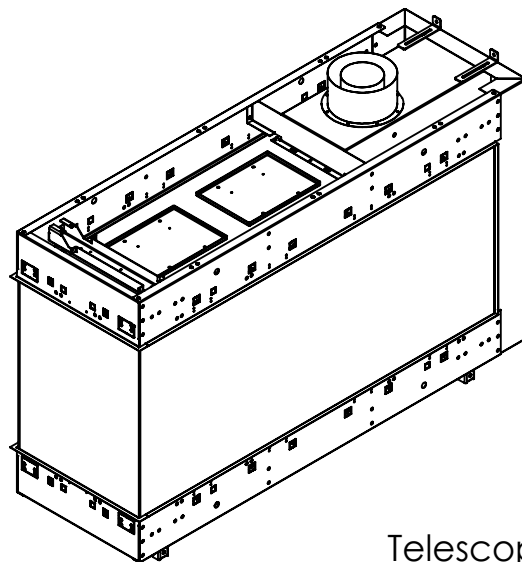
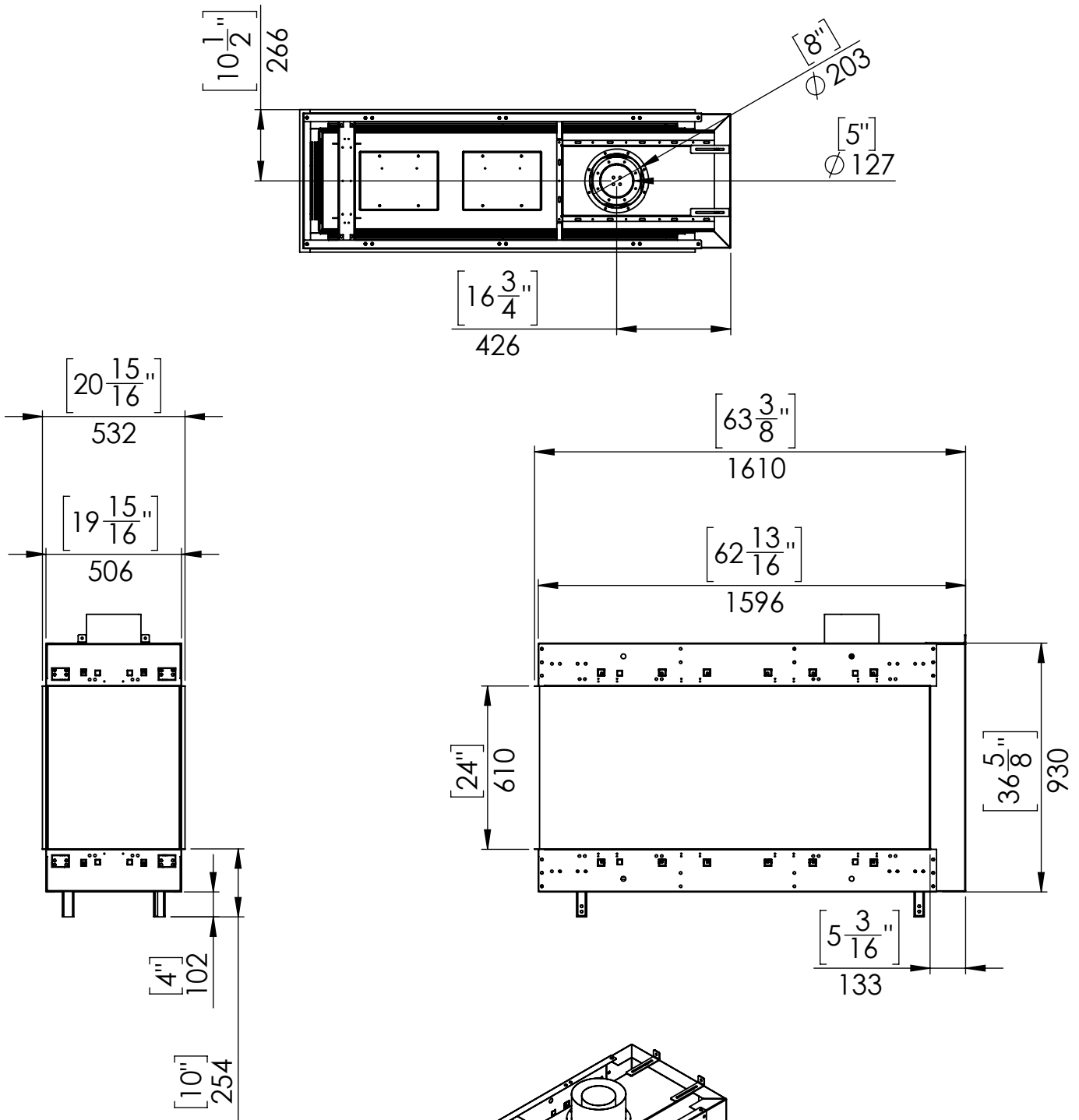

Telescopic leg ranges (from bottom of the glass): 10"-21"

Flat Installation

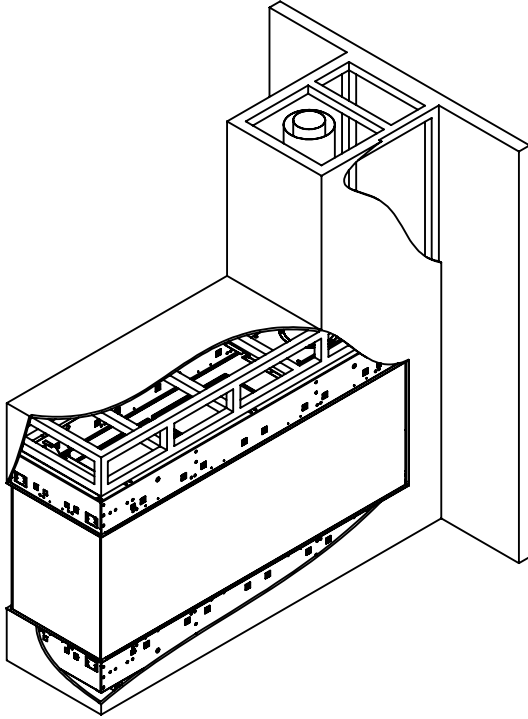

Step 1 - Basic Framing :

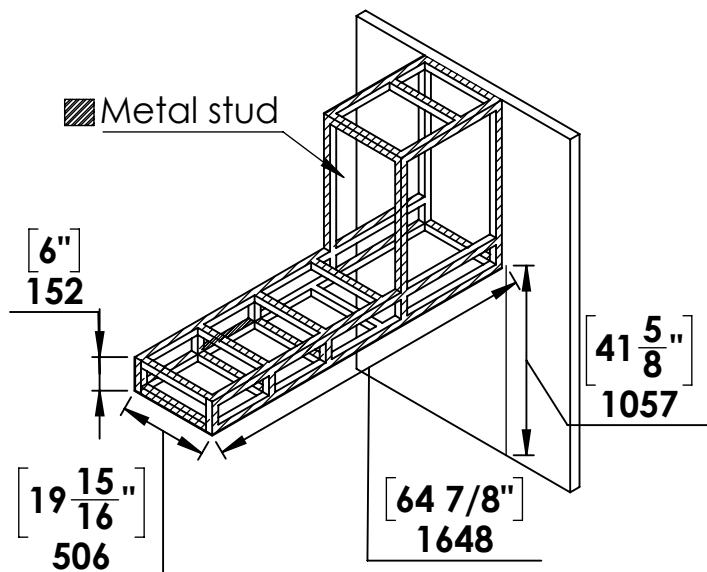

Recess Installation

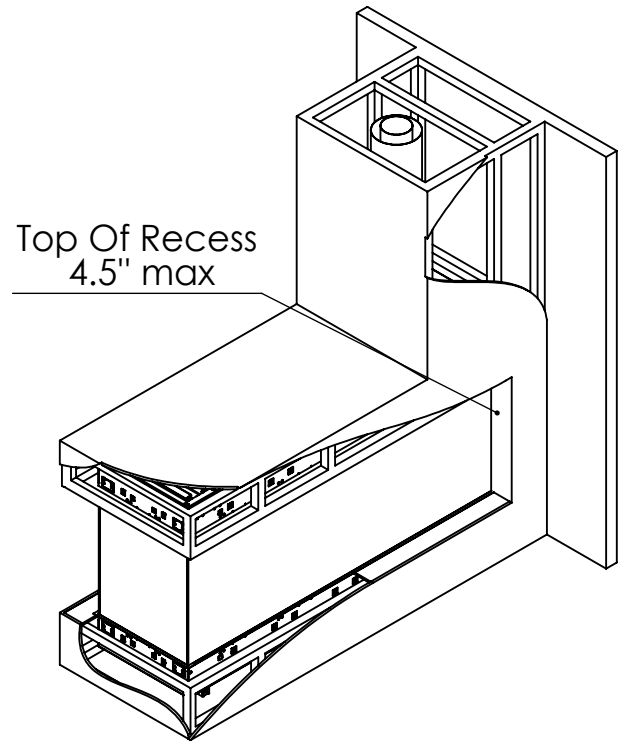

Step 1 - Basic Framing :

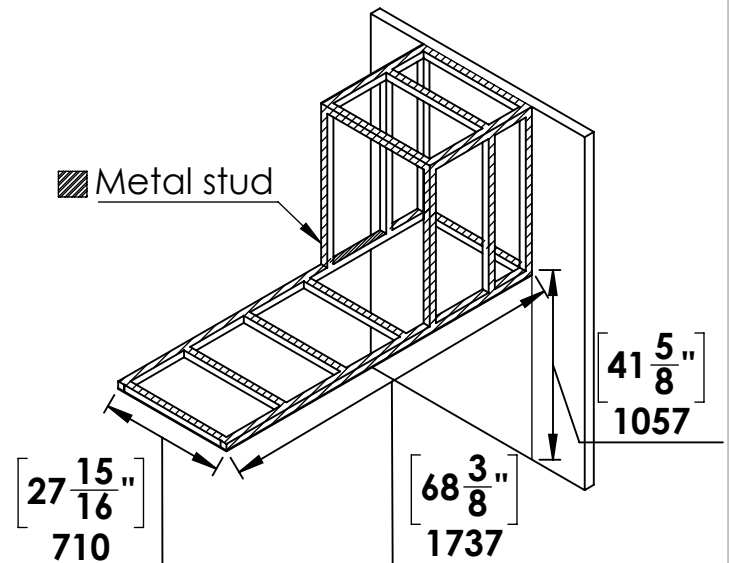

Flat Installation

Step 2 -Positioning the Fireplace:

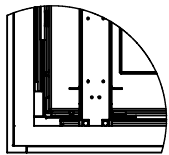
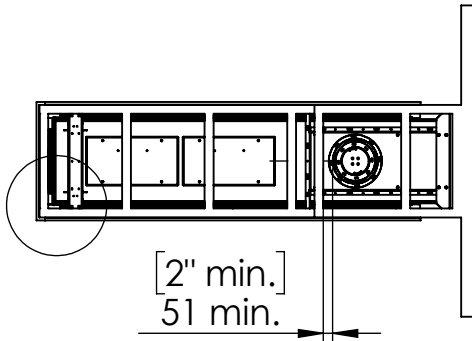

Fireplace frame finishing holder space to match wall finishing thickness

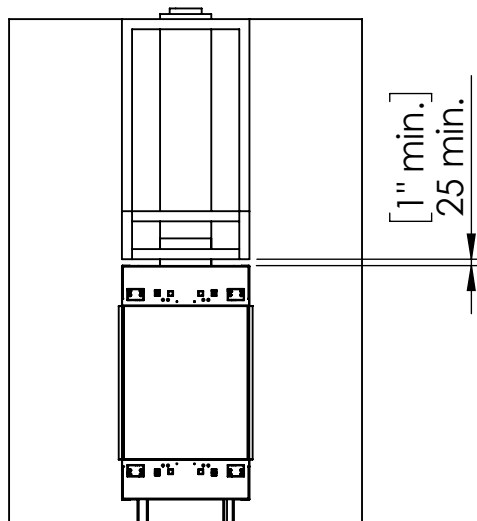

Recess Installation

Step 2 -Positioning the Fireplace:

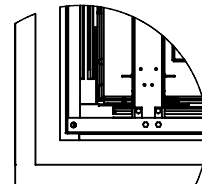
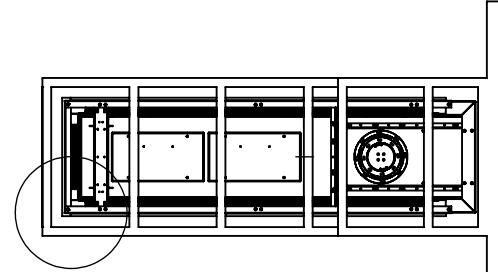

gap to match the max. length of top shelf.

[4" max.]
102 max.

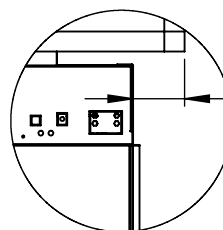
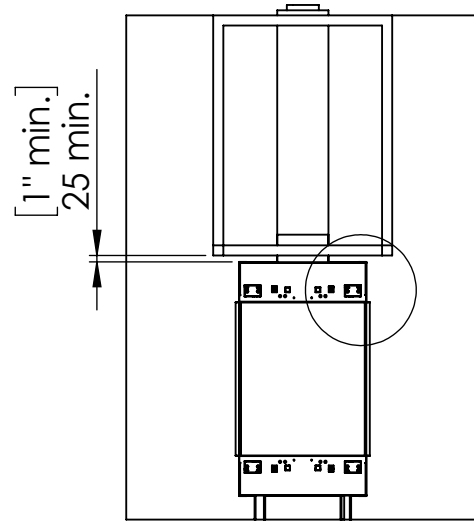

[4" max.]
102 max.

Flat Installation

Last Step - Finishing The Fireplace Wall:

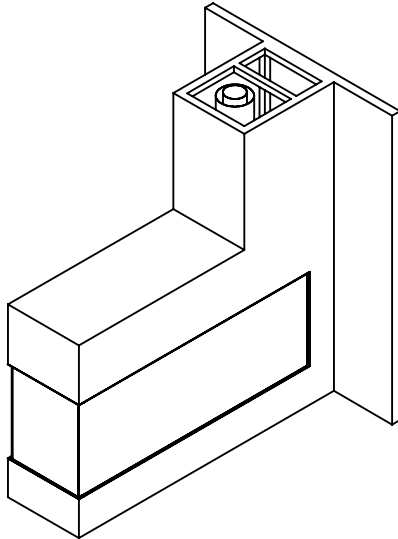

Recess Installation

Step 3 - Framing Front Studs For Recess
After positioning the Fireplace:

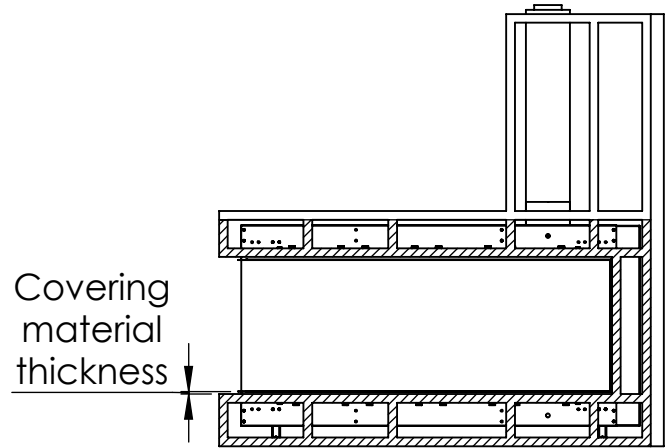

Last Step - Finishing The Fireplace Wall:

