

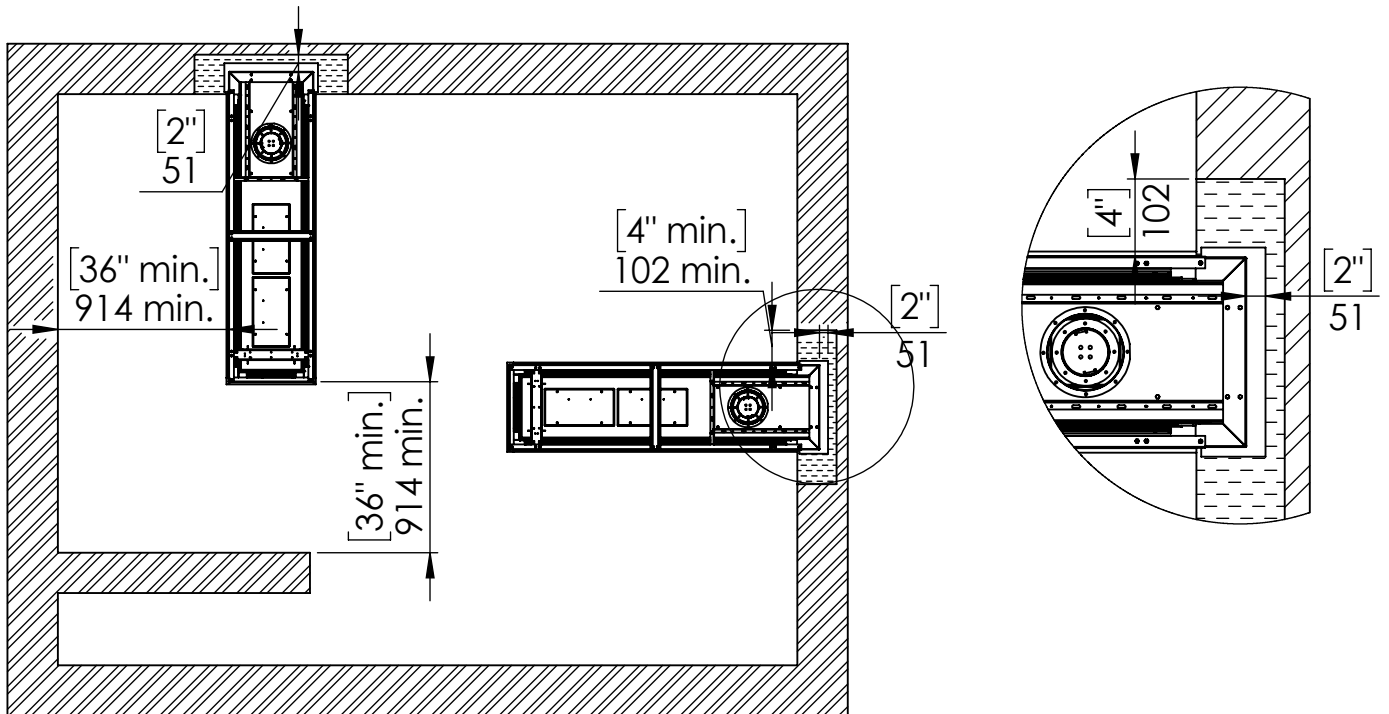

Specifications for Appliance Flare Room Definer 80

Factor	NG	LPG
Burner Type	35,105,35	35,105,35
Orifice	500,1200,500	160,260,160
BTU Max.	52200	43000
BTU min.	28000	20000
Kw/h	16.3k	13.5k
Chimney DIA.	5X8	5X8
Manifold Pressure[w.c]	3.4	8.8
Efficiency rate	82	80
Glass Size Length\Width	2020 X 420 mm	79" 8/16 X 16" 9/16'
Appliance Weigh	220Kg	485lb

Appliance Location



 Combustible Materials
 Non Combustible Materials



Flare Room Definer 80

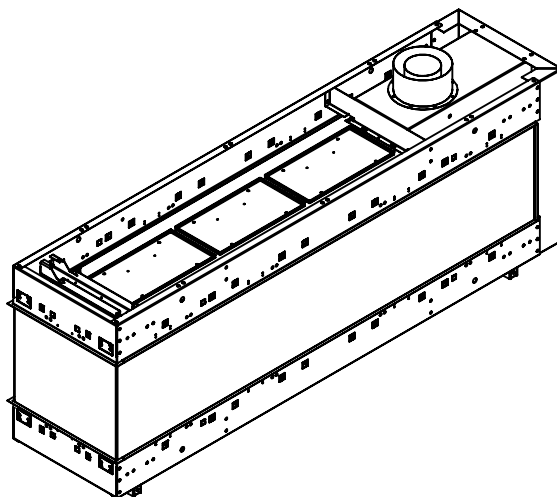
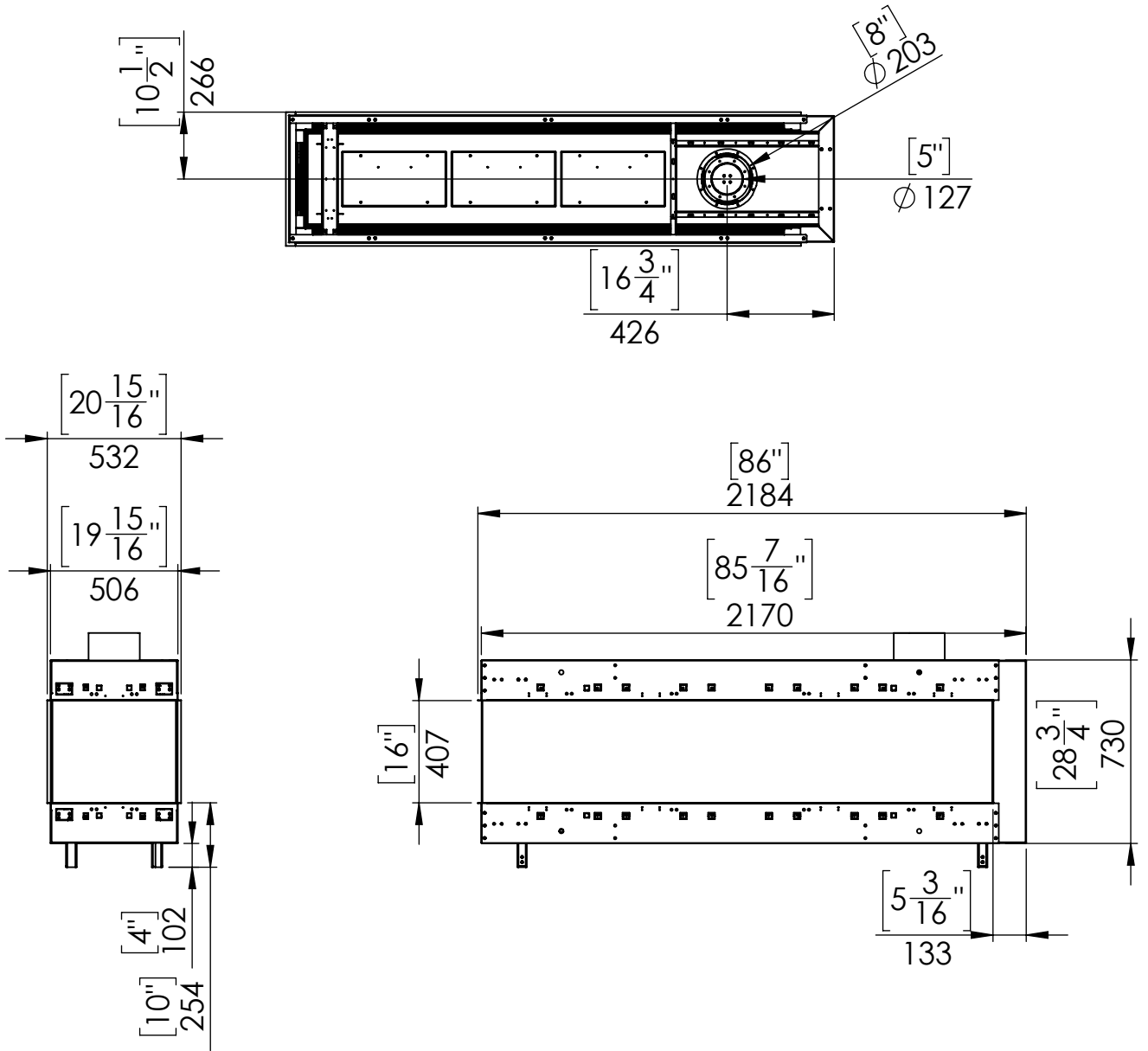

Telescopic leg ranges (from bottom of the glass): 10"-21"

Flat Installation

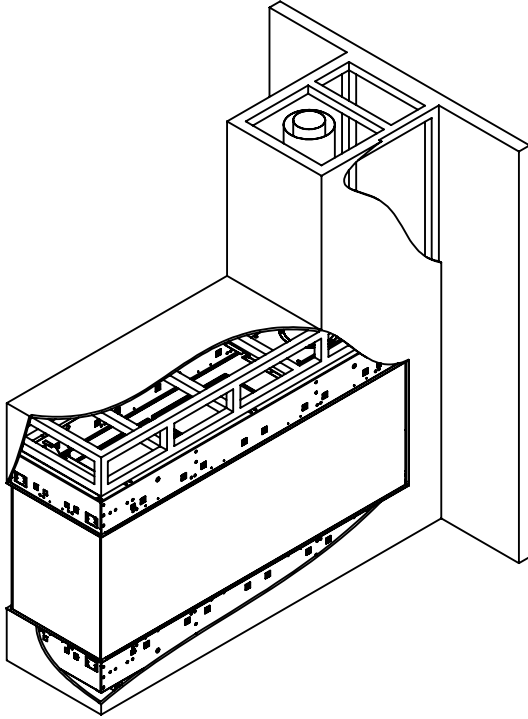

Step 1 - Basic Framing :

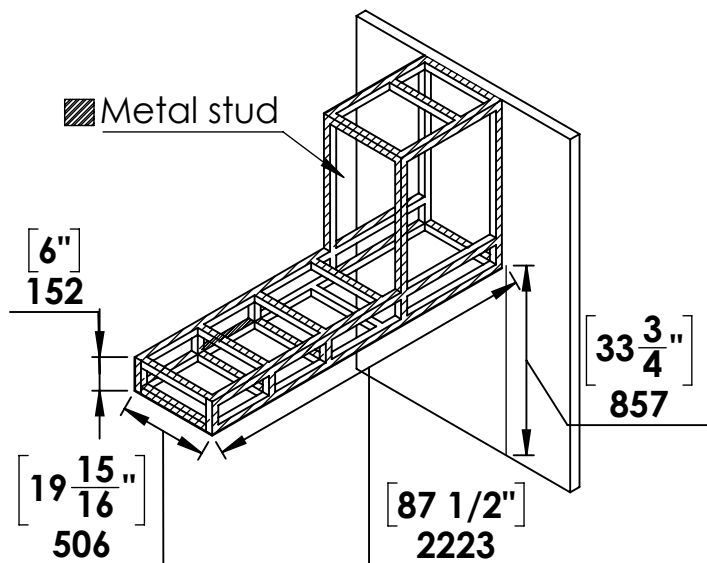

Recess Installation

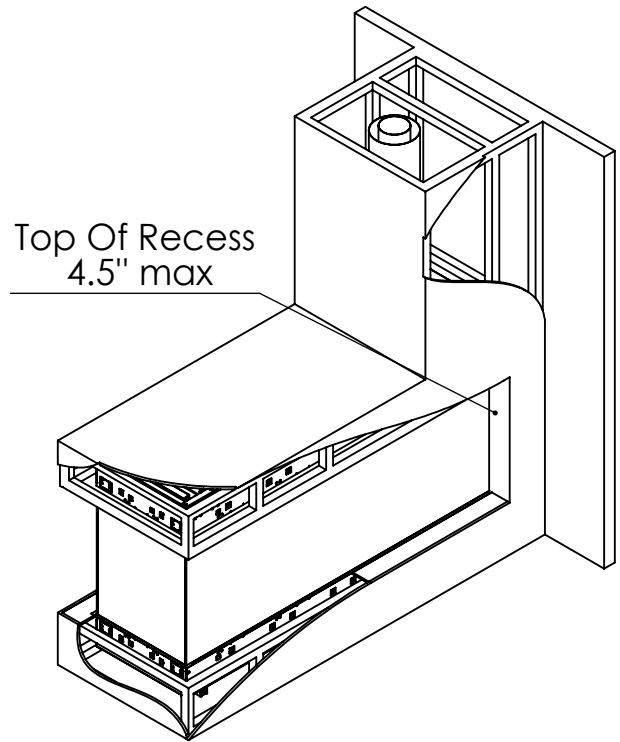

Step 1 - Basic Framing :

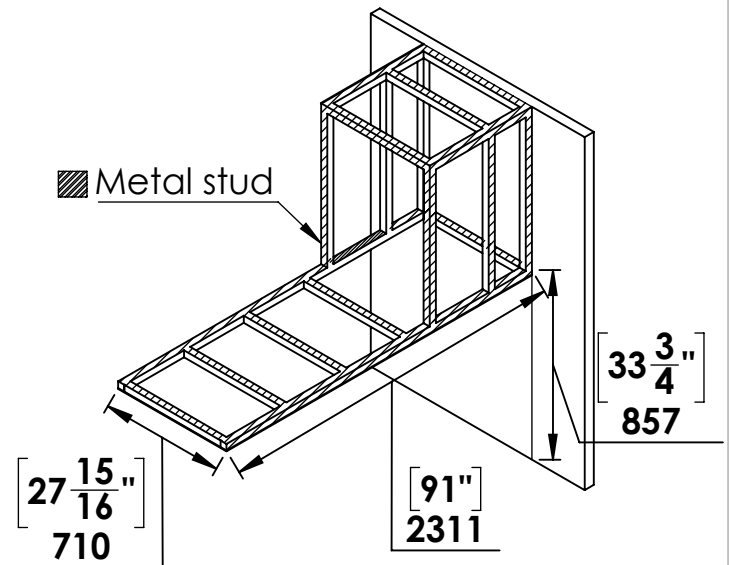

Flat Installation

Step 2 -Positioning the Fireplace:

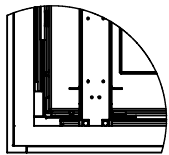
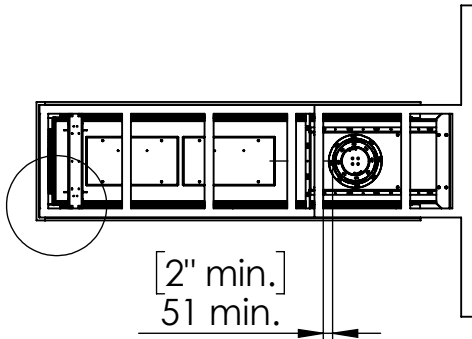

Fireplace frame finishing holder space to match wall finishing thickness

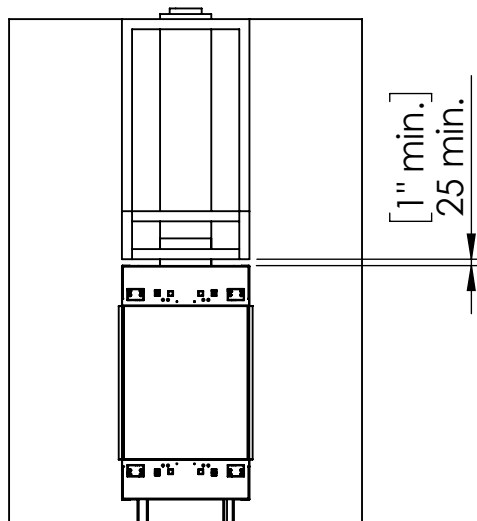

Recess Installation

Step 2 -Positioning the Fireplace:

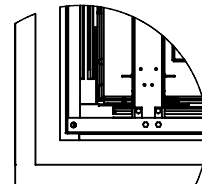
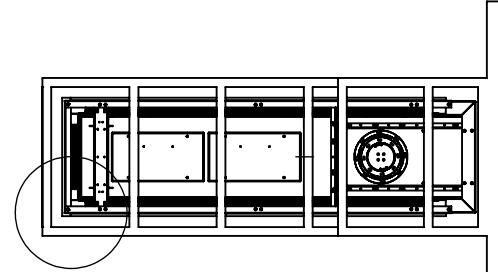

gap to match the max. length of top shelf.

[4" max.]
102 max.

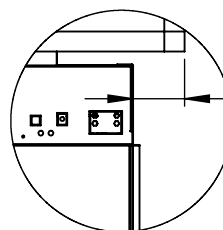
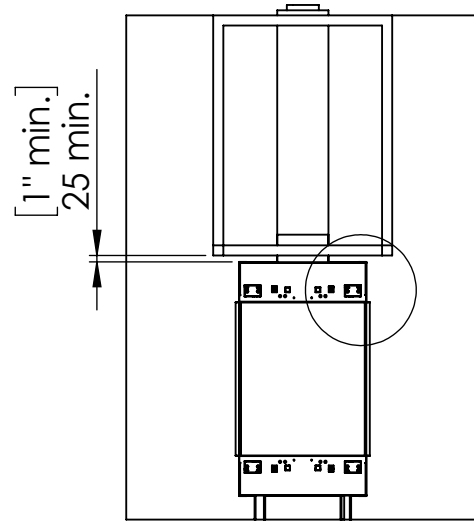

[4" max.]
102 max.

Flat Installation

Last Step - Finishing The Fireplace Wall:

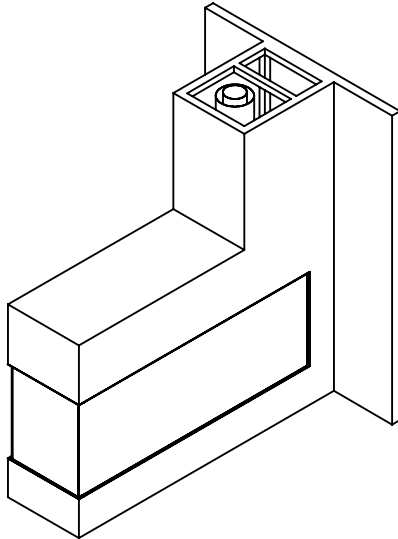

Recess Installation

Step 3 - Framing Front Studs For Recess
After positioning the Fireplace:

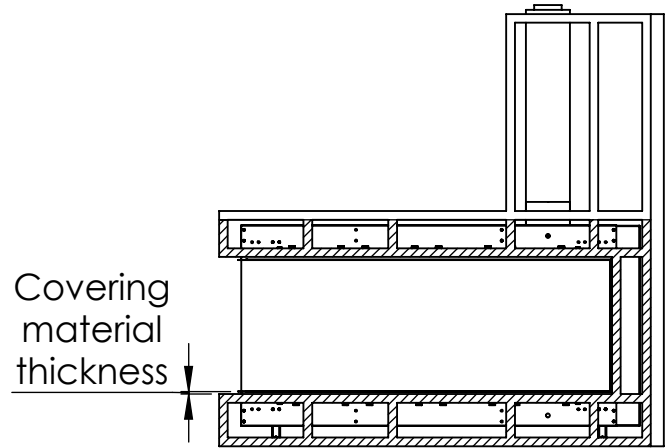

Last Step - Finishing The Fireplace Wall:

