

Telescopic Leg Range
From bottom of glass: 10"-19"

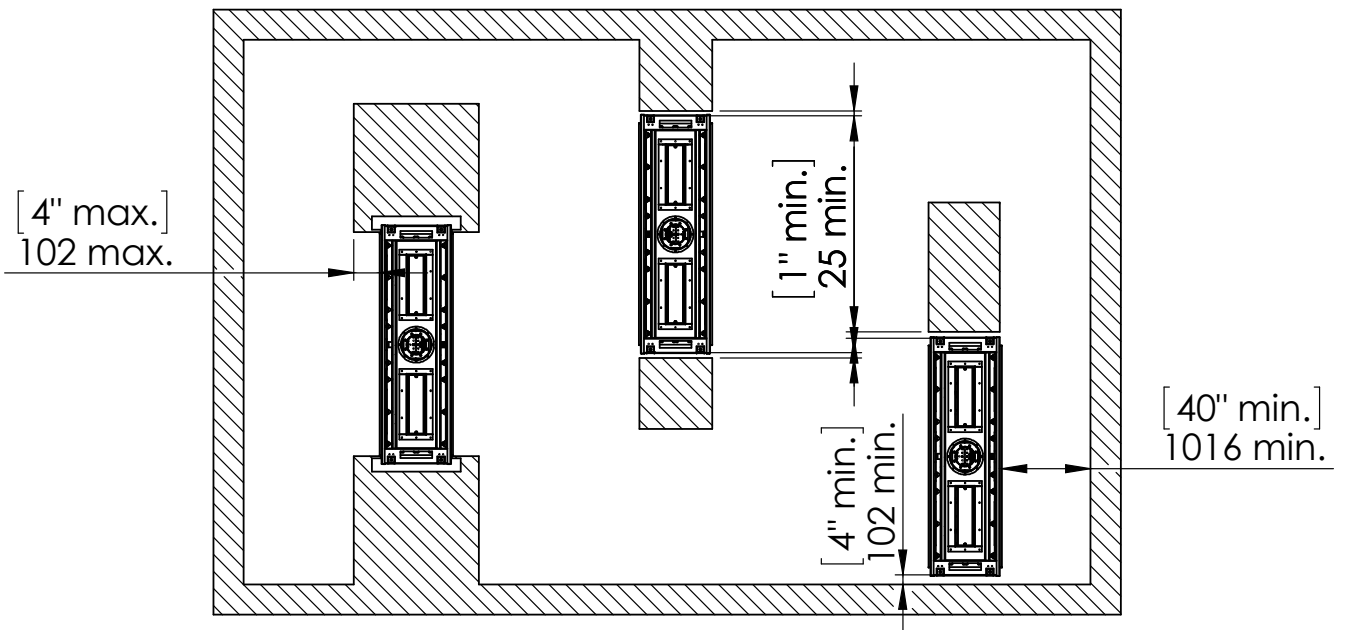

Chimney Installation

Horizontal Termination

For 5 x 8 vent size create 10" x 12" vent termination opening

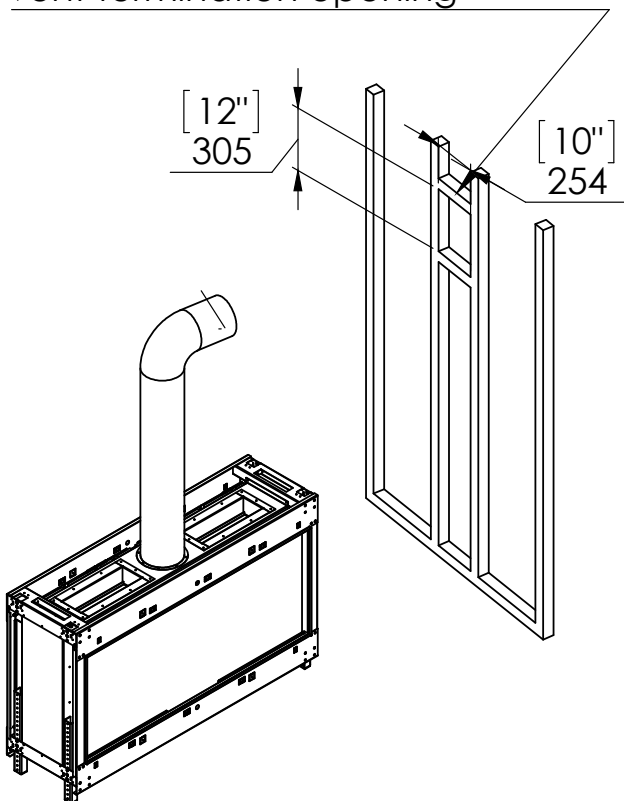

Vertical Termination

For 5 x 8 vent size create 10" x 10" vent termination opening

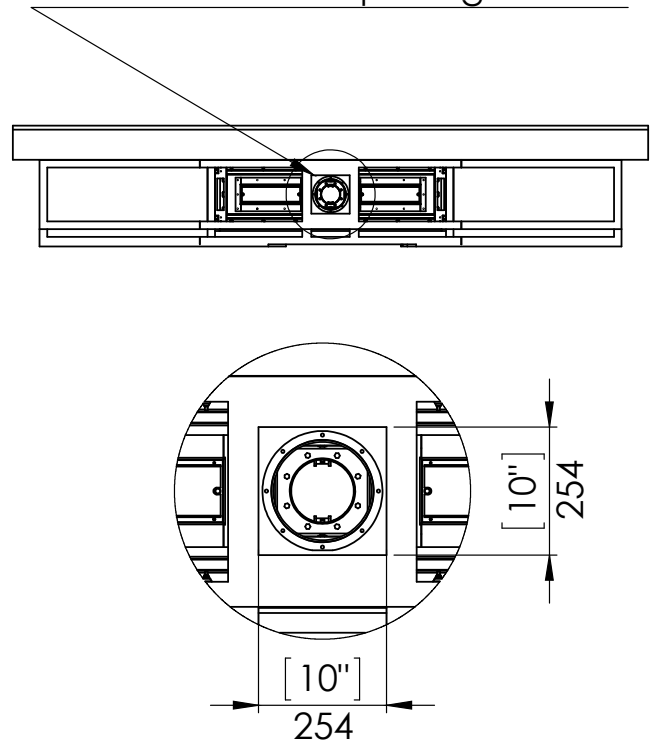

Flat Installation

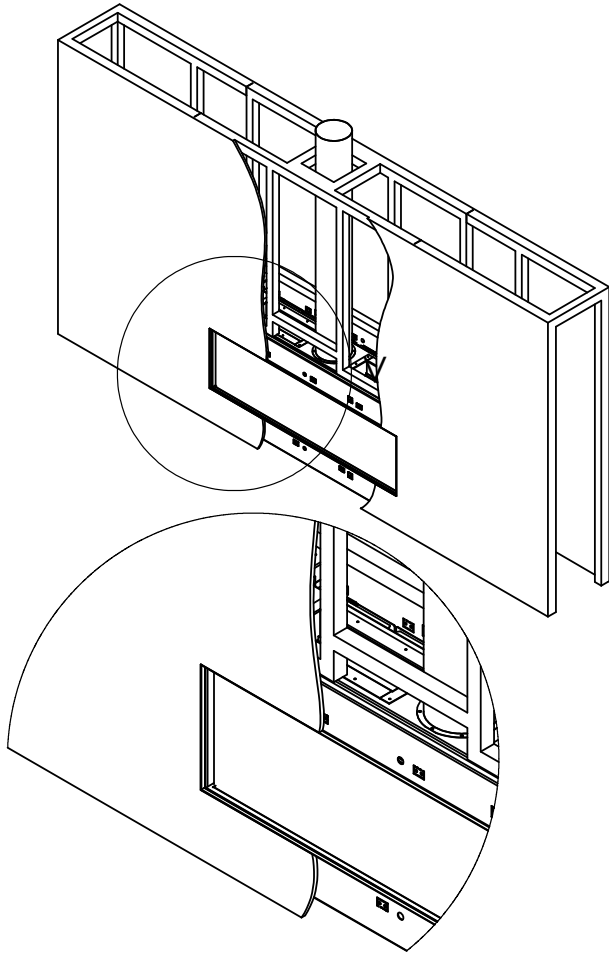

L Shape Installation

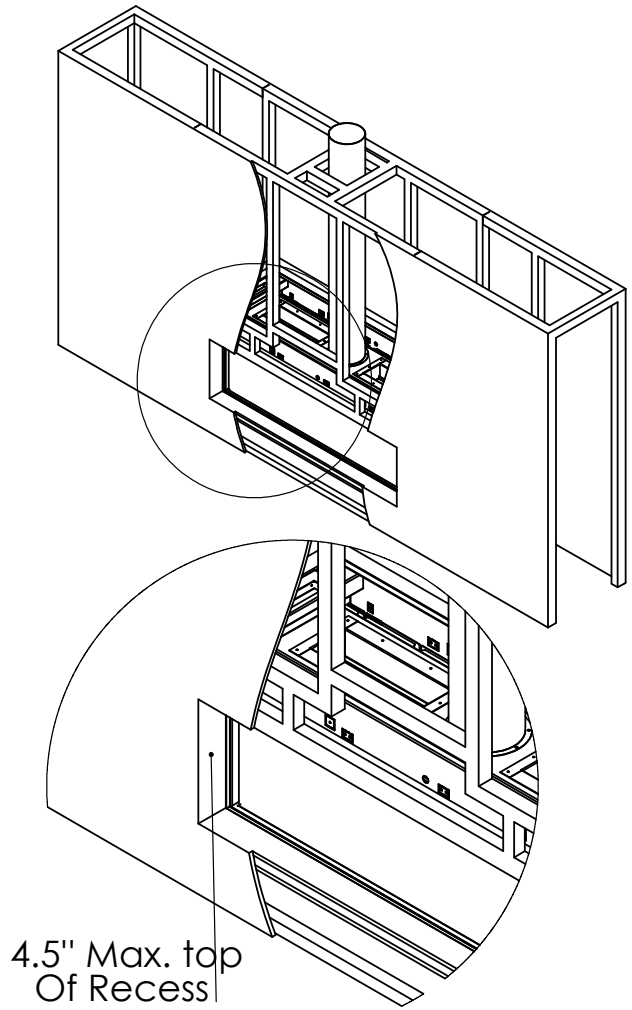

Step 1 - Basic Framing :

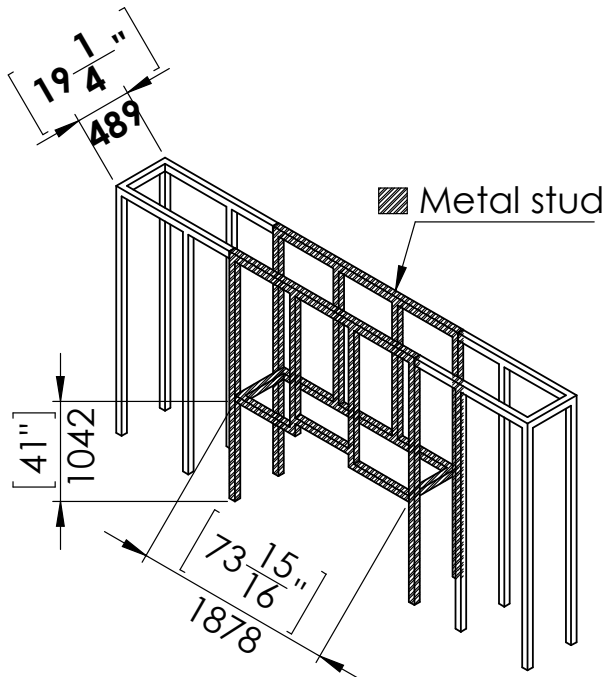

Step 1 - Basic Framing :

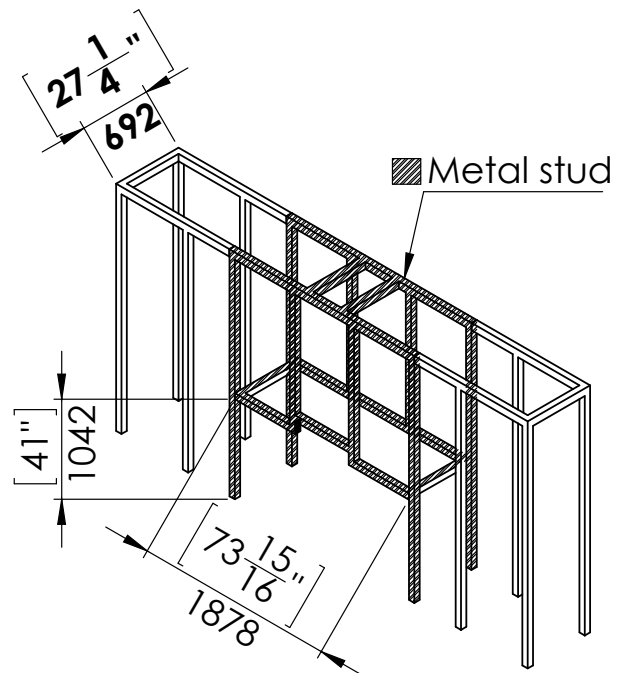

Flat Installation

Step 2 -Positioning the Fireplace:

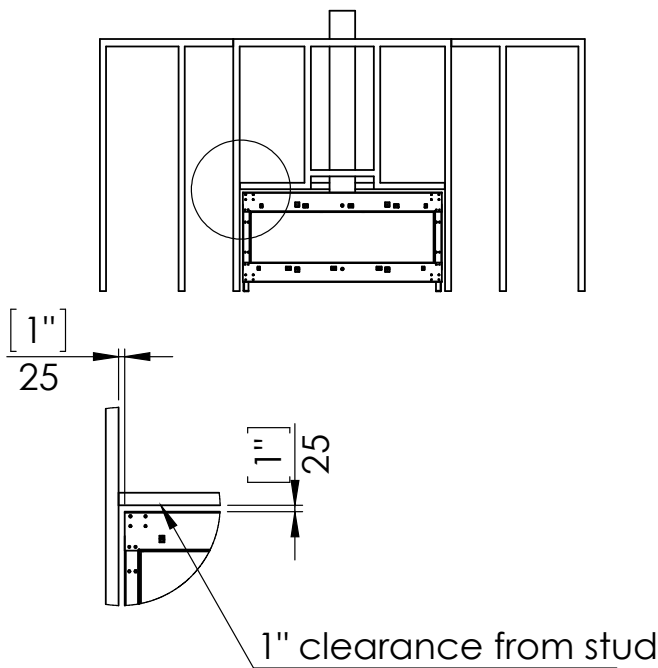
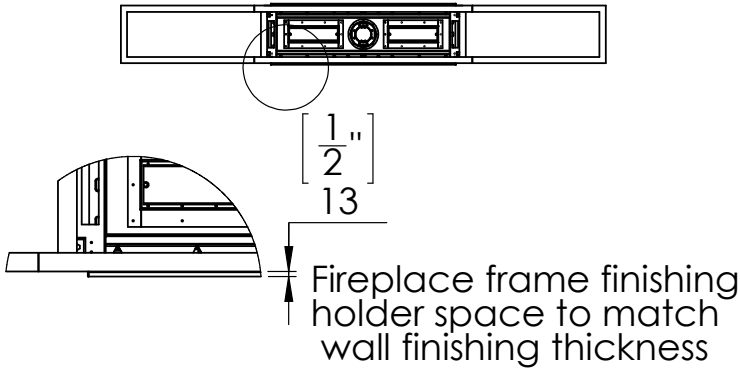

Last Step - Finishing The Fireplace Wall:

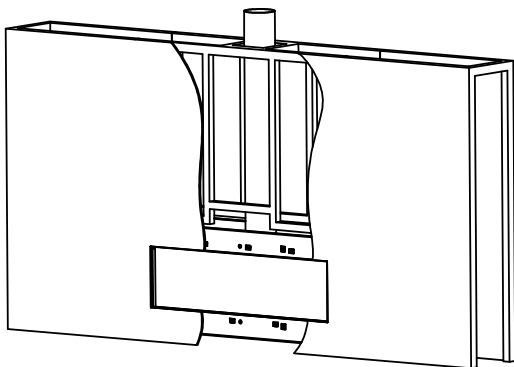

L Shape Installation

Step 2 -Positioning the Fireplace:

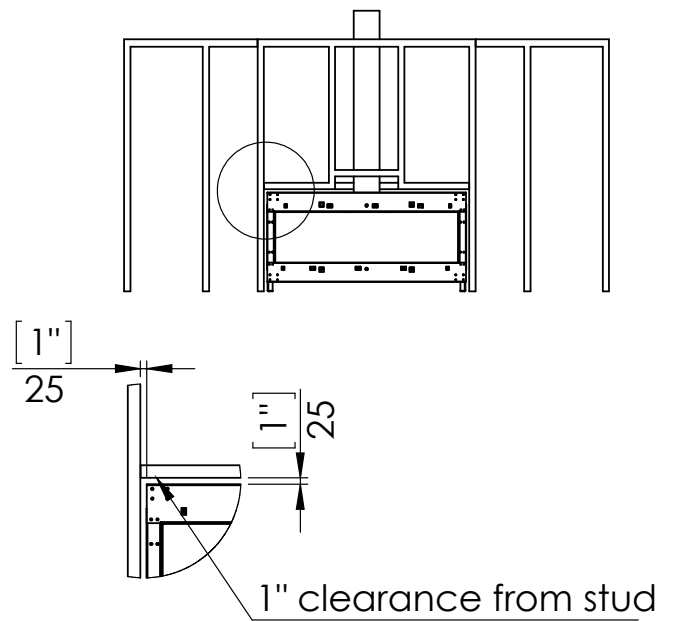
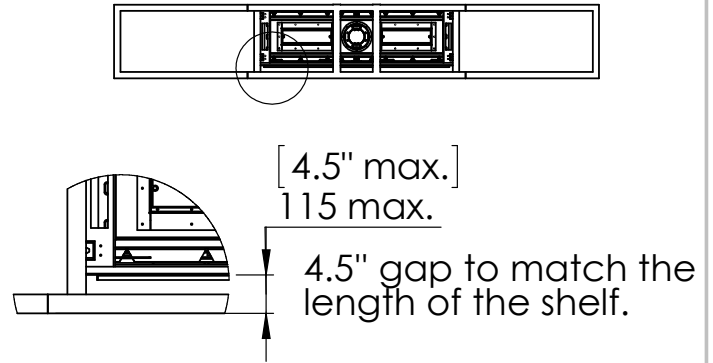

Step 3 - Framing Front Studs For L Shape:

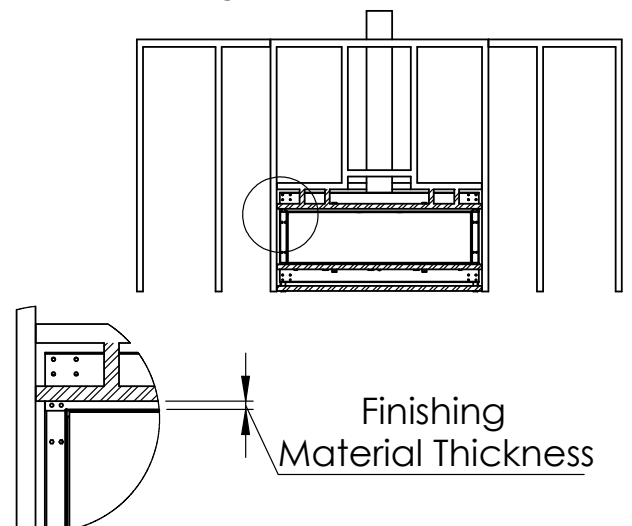

L Shape Finishing Install

Last Step - Finishing The Fireplace Wall:

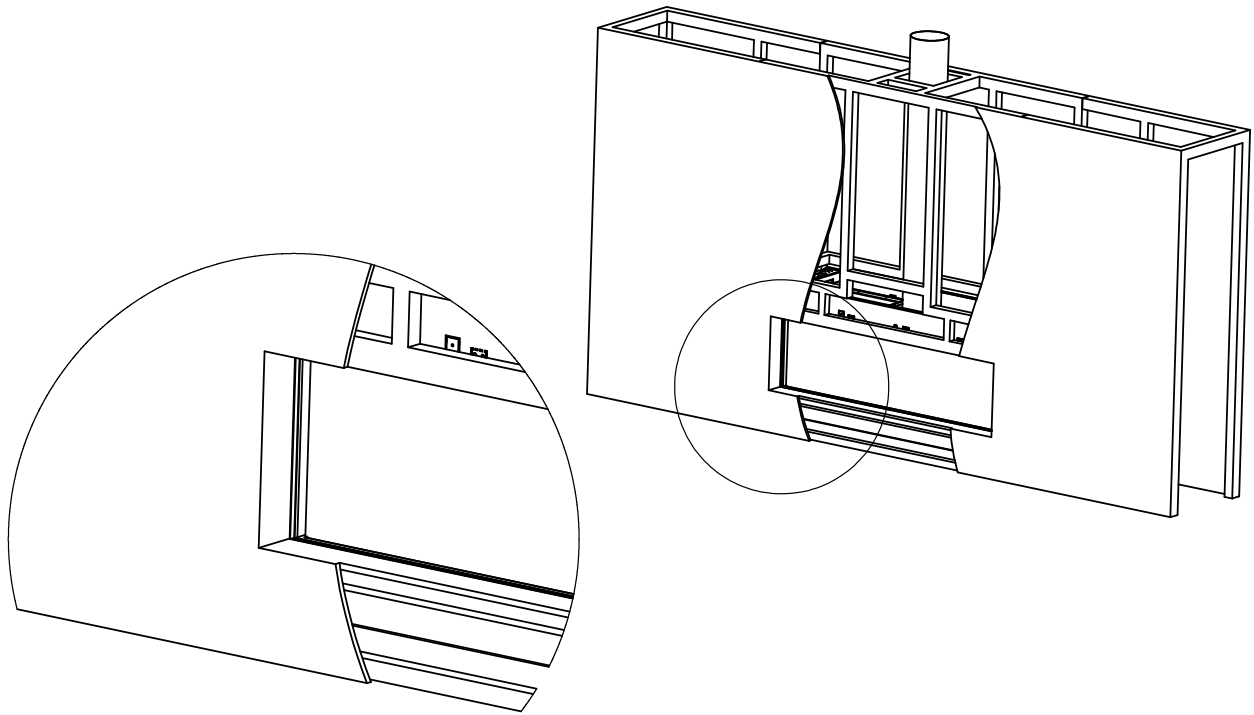

Specifications for Appliance Flare See Through 70H Commercial

Factor	NG	LPG
Burner Type	35,80,35	35,80,35
Orifice	500,1000,500	160,320,160
BTU Max.	52200	43000
BTU min.	28000	20000
Kw/h	15.3k	12.6k
Chimney DIA.	5X8	5X8
Manifold Pressure[w.c]	Screen – 3.2 Double glass - 5.2	6.7
Efficiency rate	82	79
Glass Size Length\Width	1705 X 620 mm	67" 1/8 X 24" 7/16'
Appliance Weigh	195Kg	430lb