



FLARE FIREPLACES

**GAS
DIRECT
VENT**



FRAMELESS LINEAR MODERN



FIND YOUR FLARE

Flare Fireplaces seamlessly blends modern design with functionality and efficiency. If you're in search of a breathtaking focal point or a reliable heating solution for your home or business, Flare is your go-to destination for premium fireplaces that deliver on every front.

Our sleek, frameless, linear, direct-vent fireplaces are crafted to meet the highest standards of quality and safety. With Flare Fireplaces, you'll find installation a breeze and versatility unmatched, offering over 80 models and a wide array of options.

Select from 8 distinctive styles, each available in lengths ranging from 30 to 100 inches and with glass heights of 16, 24, or 30 inches to perfectly fit your space. Invest in a Flare Fireplace and enjoy the warmth and elegance it brings for years to come, backed by our 10-year warranty.

CONTENTS

3	Key Features
5	Optional Features
6	Home Automation
7	Power Vent
8	Commercial Line
9	Summer Kit
10	Outdoor Kit
11-12	Decorative Media
13-14	Front Facing
15-16	See Through
17-18	Right Corner
19-20	Left Corner
21-22	Double Corner
23-24	Room Definer
25-26	Passage Front & See Through
27-28	Traditional
29-30	Picture Key

KEY FEATURES



STYLE CHARACTERISTICS

Six different linear presentations, each from 30-100 inches long.¹ Standard 16-inch glass height, 24-inch High Glass, or 30-inch Extra High Glass option available for all models. Frameless design. Residential and commercial use.



COOL TOUCH WALL DESIGN

All of our models are designed so surrounding walls stay relatively cool, allowing you to hang a TV or art piece closer to the fireplace with less insulation to save you time, money, and effort.



EASY INSTALL AND SERVICE

Telescopic Legs let you easily plan and adjust the fireplace height.

Easy access to the vent restrictor and air shutter allows quick calibration of flame height & color.

Smoke free paint with no burn period.

¹Room Definer from 45 to 100 inches. ²All 30 inch fireplace models come with 24-inch high glass.

BURNERS AND GAS

3D Stainless Steel or Summit burners offer a natural flame presentation. These multi-burner systems allow the flame to extend closer to the edges, or add height for taller viewing windows. Electronic Ignition. Power Adapter and Battery Backup. Natural Gas or Propane.



CERTIFICATES AND COMPLIANCE

Complying with North American standards³ as well as state requirements in CA, MA, and NY. High Efficiency ratings. Certified for use with DuraVent 3x5, 4x6, or 5x8 direct vents.⁴



QUALITY AND COMFORT

Compatible with home automation systems. Advanced programmable remote control. Easy to use wall switch. Classic Decorative Media included. 10 year warranty.



³ ANSI Z21.88 - CSA 2.33 Vented Gas Fireplace Heaters.

OPTIONAL FEATURES

COOLED GLASS

Cooled external glass serves as a sleek safety barrier while maintaining the same heat output and efficiency. Frameless corners allow a clear view to the flames. Power venting not required. Suitable for residential and commercial use.

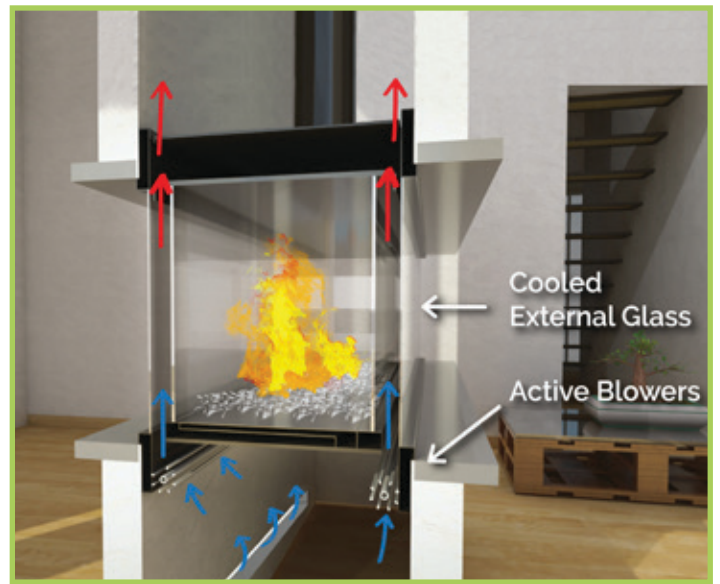

LED LIGHTING

Available in a radiant multi-colored option. Remote included.



REFLECTIVE BACK AND SIDES

Let the flames stand out against a black-mirrored ceramic glass background, adding amazing depth to any unit.

WALL TIMER

Simple wall-mounted timer. With the flexibility for mounting up to 200' away.

CUSTOM UNITS

Custom lengths and heights for special projects. Contact for more details and pricing.



HOME AUTOMATION

You can easily connect your Flare Fireplace to a new or existing home automation hub using our “Home Automation Cable”, included with every Flare Fireplace. This modern feature allows you to turn your fireplace on and off, and adds a modern twist to the heart of your smart-home.



POWER VENT

IN-LINE SYSTEM

The in-line Power Vent allows vent runs of up to 100 feet. Designed for downward or extremely long horizontal runs. The system uses DuraVent 3x5 vents.

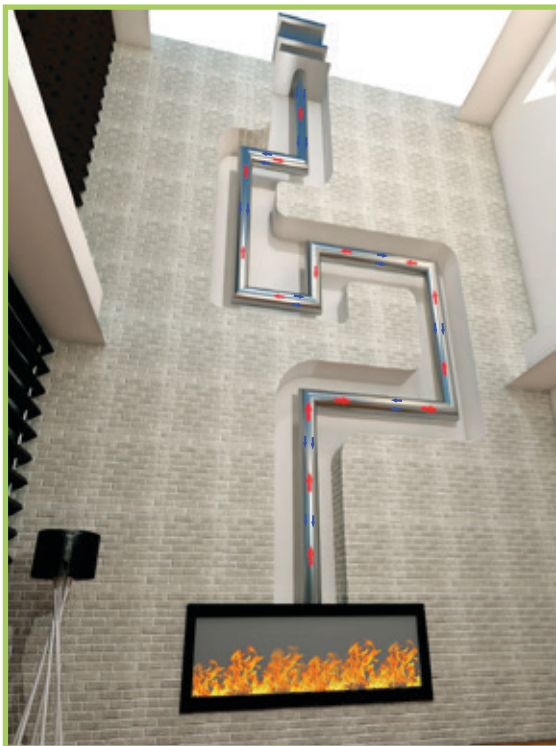

END-OF-LINE VERTICAL

The End of Line Vertical Power Vent allows vent runs of up to 100 feet. Designed for downward or extremely long horizontal runs. The system uses DuraVent 3x5 vents.

FLUSH END-OF-LINE HORIZONTAL

The End of Line Horizontal Power Vent sits flush against your external wall. It allows vent runs of up to 100 feet. Designed for downward or extremely long horizontal runs. The system uses DuraVent 3x5 vents.



COMMERCIAL LINE



Flare Fireplaces are perfect commercial use whether indoors or out. The taller glass option increases the viewing angle and the Double Glass feature comes standard for extra safety. Also included is a commercial grade gas valve so you can be confident Flare will integrate flawlessly into your restaurant, hotel, or local business.



SUMMER KIT

IN-LINE

SUMMER KIT

The perfect solution for moving heat from your fireplace chase to any outdoor termination point. Using flex pipe you can effectively run the heat your fireplace creates up to 80 feet, terminating on an exterior sidewall, allowing for operation of the fireplace without the heat it produces during the summer months.



FLUSH END-OF-LINE

SUMMER KIT

This secondary option in our Summer Kit lineup opens up even more possibilities for installation across a wider array of projects. By offering an end of line horizontal termination you no longer have to worry about where to place the Summer Kit fan for service. You also reduce the noise level by allowing the installation of the fan to be further away from the fireplace.

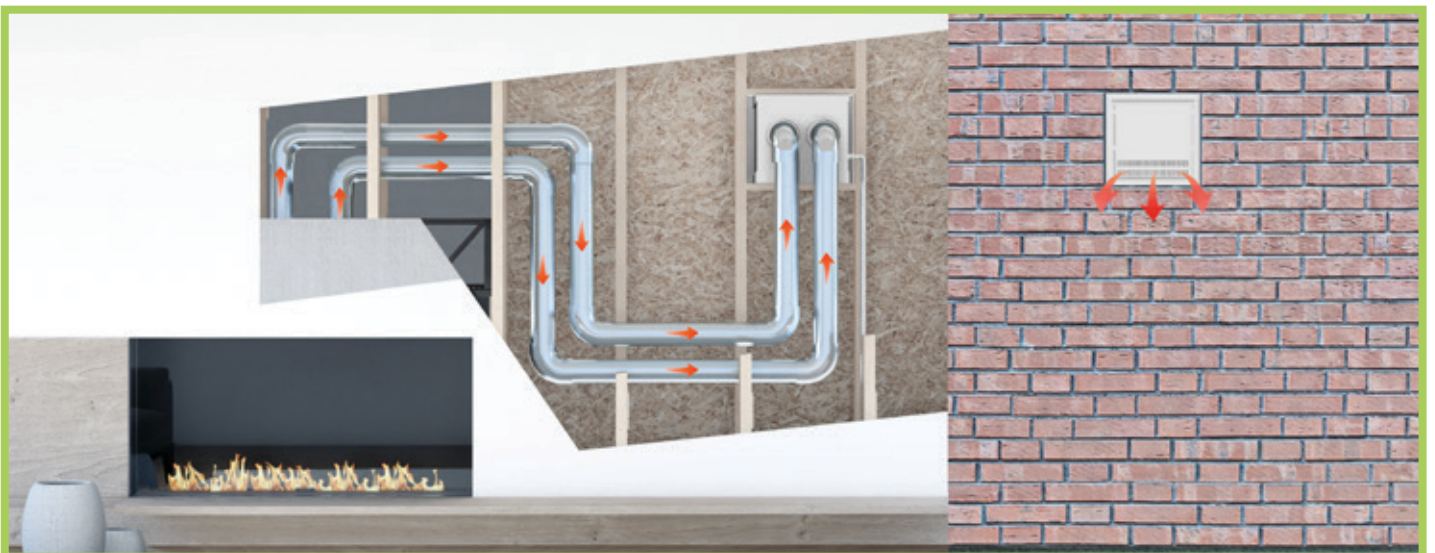

OUTDOOR KIT

*The Flare Outdoor Kit provides the freedom to enjoy a Flare Fireplace in your favorite setting. Use a Passage unit as the perfect centerpiece for your relaxing outside patio, or install the See Through Fireplace on an external wall for a unique, multi-purpose window. Our specially designed weatherproof kit comes with the same 10 year warranty as the rest of our line.

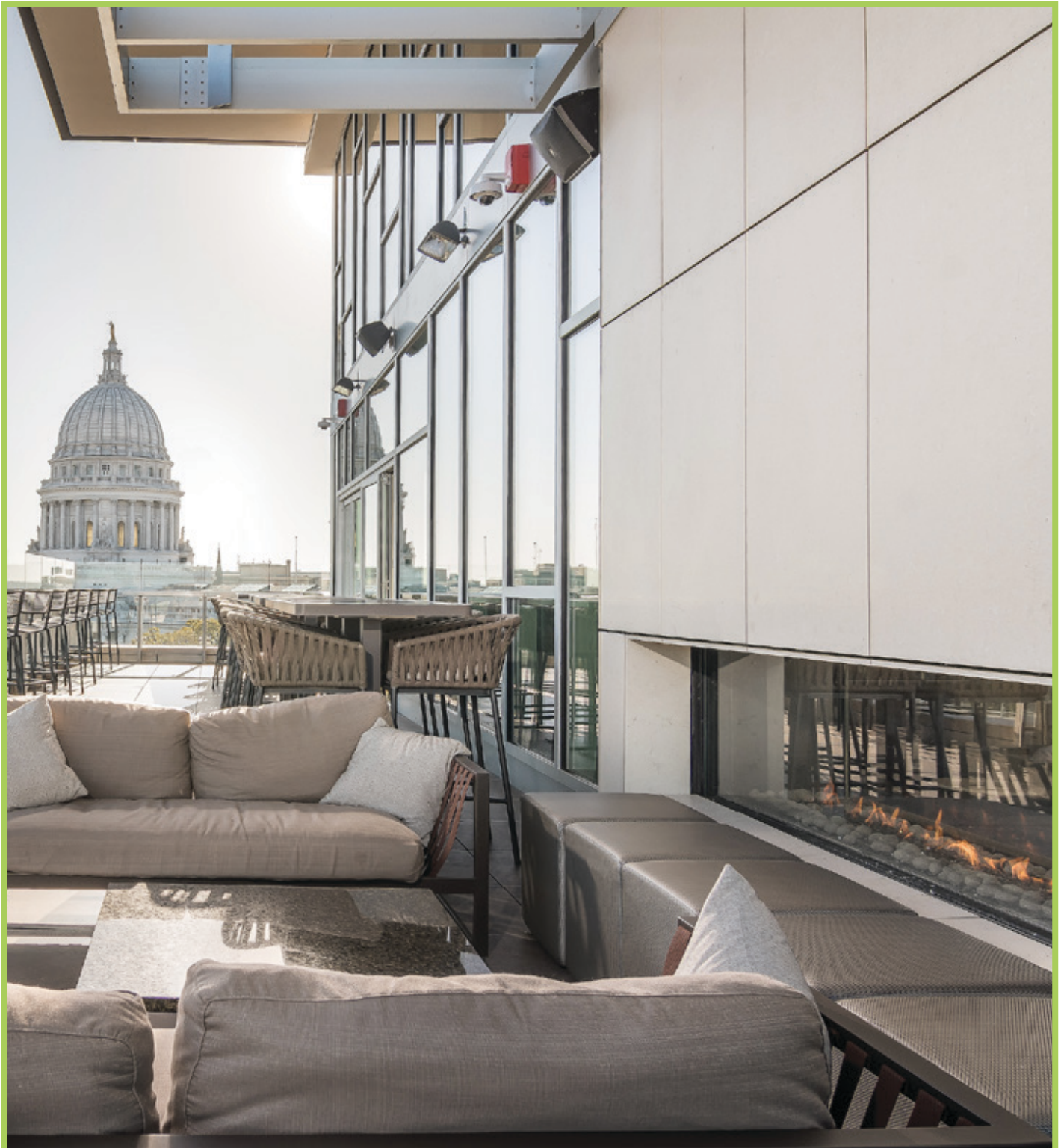

*Available only for See Through and Passage models.

DECORATIVE MEDIA

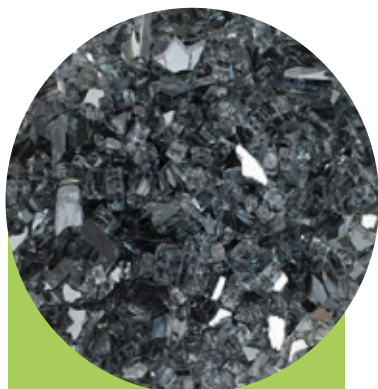

Reflective Silver Fireglass

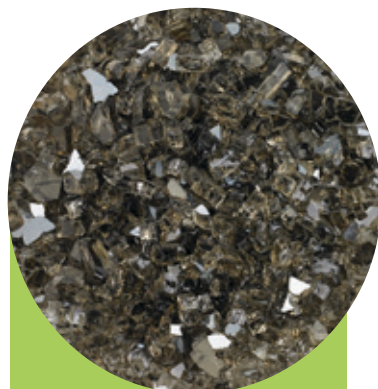

Reflective Bronze Fireglass



Reflective Ice Fireglass



Clear Fireglass

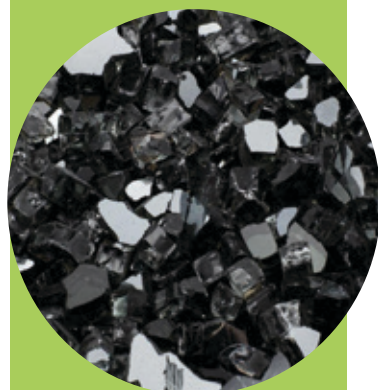

Black Fireglass



Gold Fireglass



Chestnut Fireglass

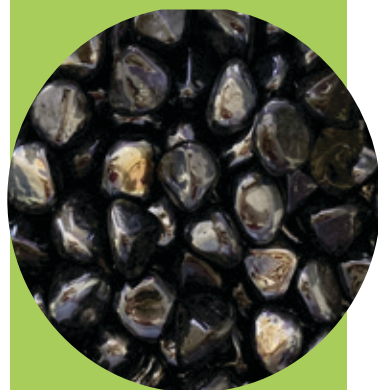

Black Zircon Diamonds

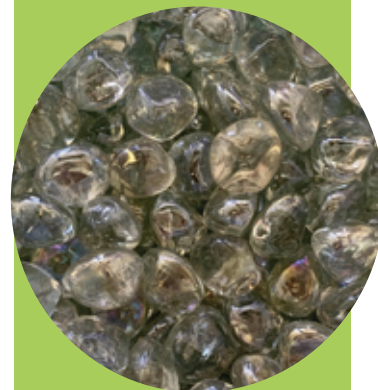

Raindrop Diamonds



White Ceramic Pebbles



Black Ceramic Pebbles



Mixed-size Earth Pebbles



Cottage White Stones



Premium Black Stones



Mixed Stone Balls



Cape Grey Stone Balls Mix



White Stone Balls



Black Stone Balls



Tan Embers



Black Embers



Ceramic Logs



Ceramic Branches



Birchwood



Driftwood

FRONT FACING

Ideal for modern and contemporary rooms, replacing an existing fireplace or as a new installation. Available in three different glass heights and widths ranging from 30 to 100 inches, giving a sleek linear look. Indoor & outdoor options available.



SPECIFICATIONS

Model	BTU/hr (max)	BTU/hr (min)	Efficiency
Flare-FF-30-H	34,000	18,500	79.5 %
Flare-FF-45-R/H/EH	36,800	22,000	79.2 %
Flare-FF-50-R/H/EH	47,000	22,750	79.3 %
Flare-FF-60-R/H/EH	50,000	28,000	79.2 %
Flare-FF-70-R/H/EH	52,200	28,000	79.8 %
Flare-FF-80-R/H/EH	55,700	31,000	79.7 %
Flare-FF-100-R/H/EH	60,000	32,500	80.3 %

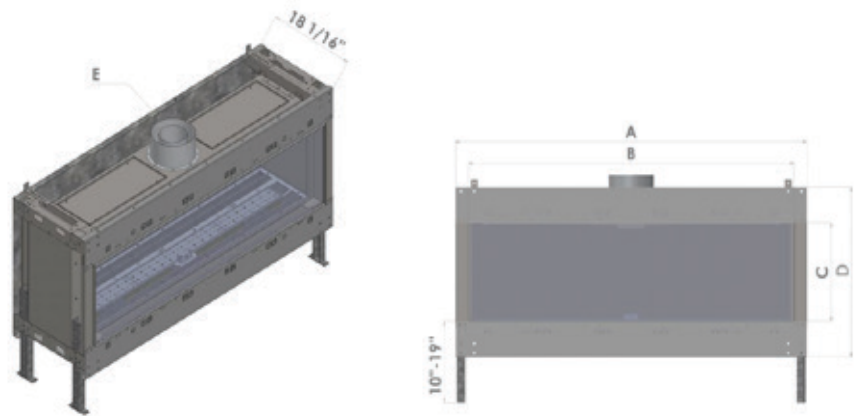

A: Full Width B: Opening Width C: Opening Height
 D: Fireplace Height, Minus Legs E: Vent Pipe Diameter

Model	A	B	C	D	E
Flare-FF-45	45 9/16	41 4/16	16	28	4x6
Flare-FF-50	52 5/16	47 15/16	16	28	5x8
Flare-FF-60	62 2/16	57 13/16	16	28	5x8
Flare-FF-70	72 3/16	67 10/16	16	28	5x8
Flare-FF-80	84 9/16	80 4/16	16	28	5x8
Flare-FF-100	101 8/16	97 3/16	16	28	5x8
*Flare-FF-30-H	32 10/16	28 4/16	24	35 14/16	4x6
Flare-FF-45-H	45 9/16	41 4/16	24	35 14/16	4x6
Flare-FF-50-H	52 5/16	47 15/16	24	35 14/16	5x8
Flare-FF-60-H	62 2/16	57 13/16	24	35 14/16	5x8
Flare-FF-70-H	72 3/16	67 10/16	24	35 14/16	5x8
Flare-FF-80-H	84 9/16	80 4/16	24	35 14/16	5x8
Flare-FF-100-H	101 8/16	97 3/16	24	35 14/16	5x8
Flare-FF-45-EH	45 9/16	41 4/16	30	42 1/8	4x6
Flare-FF-50-EH	52 5/16	47 15/16	30	42 1/8	5x8
Flare-FF-60-EH	62 2/16	57 13/16	30	42 1/8	5x8
Flare-FF-70-EH	72 3/16	67 10/16	30	42 1/8	5x8
Flare-FF-80-EH	84 9/16	80 4/16	30	42 1/8	5x8
Flare-FF-100-EH	101 8/16	97 3/16	30	42 1/8	5x8

*Flare-FF-30-H is only available in 24" glass height

SEE THROUGH

Stylish, minimalist design that allows fireplace viewing from two adjacent rooms. Available in three different glass heights: 16", 24", and 30". Available for indoor and outdoor, perfect for mounting a TV above.



SPECIFICATIONS



Model	BTU/hr (max)	BTU/hr (min)	Efficiency
Flare-ST-30-H	34,000	18,500	79.5 %
Flare-ST-45-R/H/EH	36,800	22,000	79.2 %
Flare-ST-50-R/H/EH	47,000	22,750	79.9 %
Flare-ST-60-R/H/EH	50,000	28,000	79.6 %
Flare-ST-70-R/H/EH	52,200	28,000	79.4 %
Flare-ST-80-R/H/EH	55,700	31,000	79.6 %
Flare-ST-100-R/H/EH	60,000	32,500	80.1 %

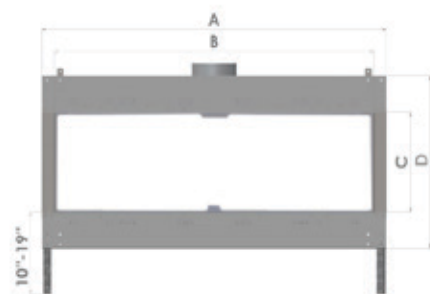
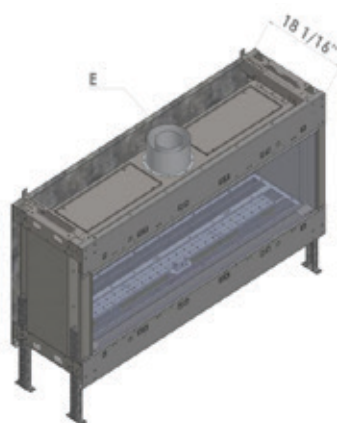

A: Full Width B: Opening Width C: Opening Height
 D: Fireplace Height, Minus Legs E: Vent Pipe Diameter

Model	A	B	C	D	E
Flare-ST-45	45 13/16	41 4/16	16	28	4x6
Flare-ST-50	52 8/16	47 5/16	16	28	5x8
Flare-ST-60	62 5/16	57 13/16	16	28	5x8
Flare-ST-70	72 3/16	67 10/16	16	28	5x8
Flare-ST-80	84 12/16	80 4/16	16	28	5x8
Flare-ST-100	101 11/16	97 3/16	16	28	5x8
*Flare-ST-30-H	32 13/16	28 4/16	24	35 14/16	4x6
Flare-ST-45-H	45 13/16	41 4/16	24	35 14/16	4x6
Flare-ST-50-H	52 8/16	47 5/16	24	35 14/16	5x8
Flare-ST-60-H	62 5/16	57 13/16	24	35 14/16	5x8
Flare-ST-70-H	72 3/16	67 10/16	24	35 14/16	5x8
Flare-ST-80-H	84 12/16	80 4/16	24	35 14/16	5x8
Flare-ST-100-H	101 11/16	97 3/16	24	35 14/16	5x8
Flare-ST-45-EH	45 13/16	41 4/16	30	42 1/8	5x8
Flare-ST-50-EH	52 8/16	47 5/16	30	42 1/8	5x8
Flare-ST-60-EH	62 5/16	57 13/16	30	42 1/8	5x8
Flare-ST-70-EH	72 3/16	67 10/16	30	42 1/8	5x8
Flare-ST-80-EH	84 12/16	80 4/16	30	42 1/8	5x8
Flare-ST-100-EH	101 11/16	97 3/16	30	42 1/8	5x8

*Flare-ST-30-H is only available in 24" glass height

RIGHT CORNER

The right corner fireplace allows more viewing angles with its innovative design. The frameless glass corner attracts the eye, making it the center of attention. A luxurious fireplace experience, clean design, superior build quality and features.



SPECIFICATIONS



Model	BTU/hr (max)	BTU/hr (min)	Efficiency
Flare-RC-30-H	34,000	18,500	79.4 %
Flare-RC-45-R/H/EH	36,800	22,000	79.7 %
Flare-RC-50-R/H/EH	47,000	22,750	79.8 %
Flare-RC-60-R/H/EH	50,000	28,000	79.8 %
Flare-RC-70-R/H/EH	52,200	28,000	79.9 %
Flare-RC-80-R/H/EH	55,700	31,000	80.2 %
Flare-RC-100-R/H/EH	60,000	32,500	80.5 %

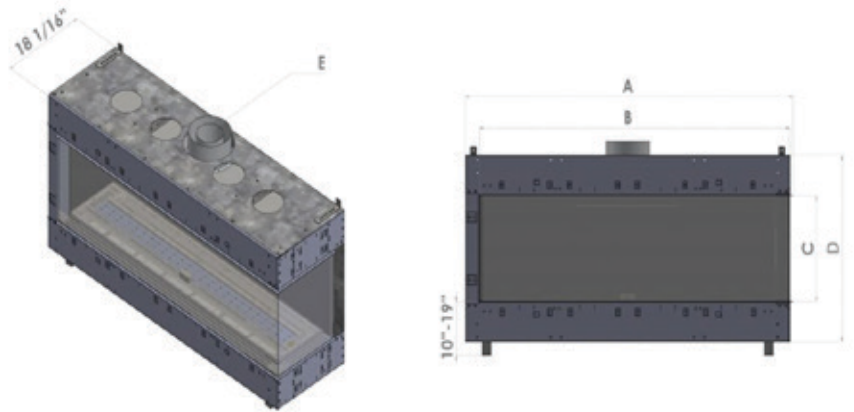

A: Full Width B: Opening Width C: Opening Height
 D: Fireplace Height, Minus Legs E: Vent Pipe Diameter

Model	A	B	C	D	E
Flare-RC-45	43 9/16	41 1/16	16	28	4x6
Flare-RC-50	50 4/16	47 13/16	16	28	5x8
Flare-RC-60	60 1/16	57 10/16	16	28	5x8
Flare-RC-70	69 15/16	67 8/16	16	28	5x8
Flare-RC-80	82 8/16	80 1/16	16	28	5x8
Flare-RC-100	99 7/16	97	16	28	5x8
*Flare-RC-30-H	30 9/16	28 8/16	24	35 14/16	4x6
Flare-RC-45-H	43 9/16	41 1/16	24	35 14/16	4x6
Flare-RC-50-H	50 4/16	47 13/16	24	35 14/16	5x8
Flare-RC-60-H	60 1/16	57 10/16	24	35 14/16	5x8
Flare-RC-70-H	69 15/16	67 8/16	24	35 14/16	5x8
Flare-RC-80-H	82 8/16	80 1/16	24	35 14/16	5x8
Flare-RC-100-H	99 7/16	97	24	35 14/16	5x8
Flare-RC-45-EH	43 9/16	41 1/16	30	42 3/16	5x8
Flare-RC-50-EH	50 4/16	47 13/16	30	42 3/16	5x8
Flare-RC-60-EH	60 1/16	57 10/16	30	42 3/16	5x8
Flare-RC-70-EH	69 15/16	67 8/16	30	42 3/16	5x8
Flare-RC-80-EH	82 8/16	80 1/16	30	42 3/16	5x8
Flare-RC-100-EH	99 7/16	97	30	42 3/16	5x8

*Flare-RC-30-H is only available in 24" glass height

LEFT CORNER

The left corner fireplace allows more viewing angles with its innovative design. The frameless glass corner attracts the eye, making it the center of attention. A luxurious fireplace experience, clean design, superior build quality and features.

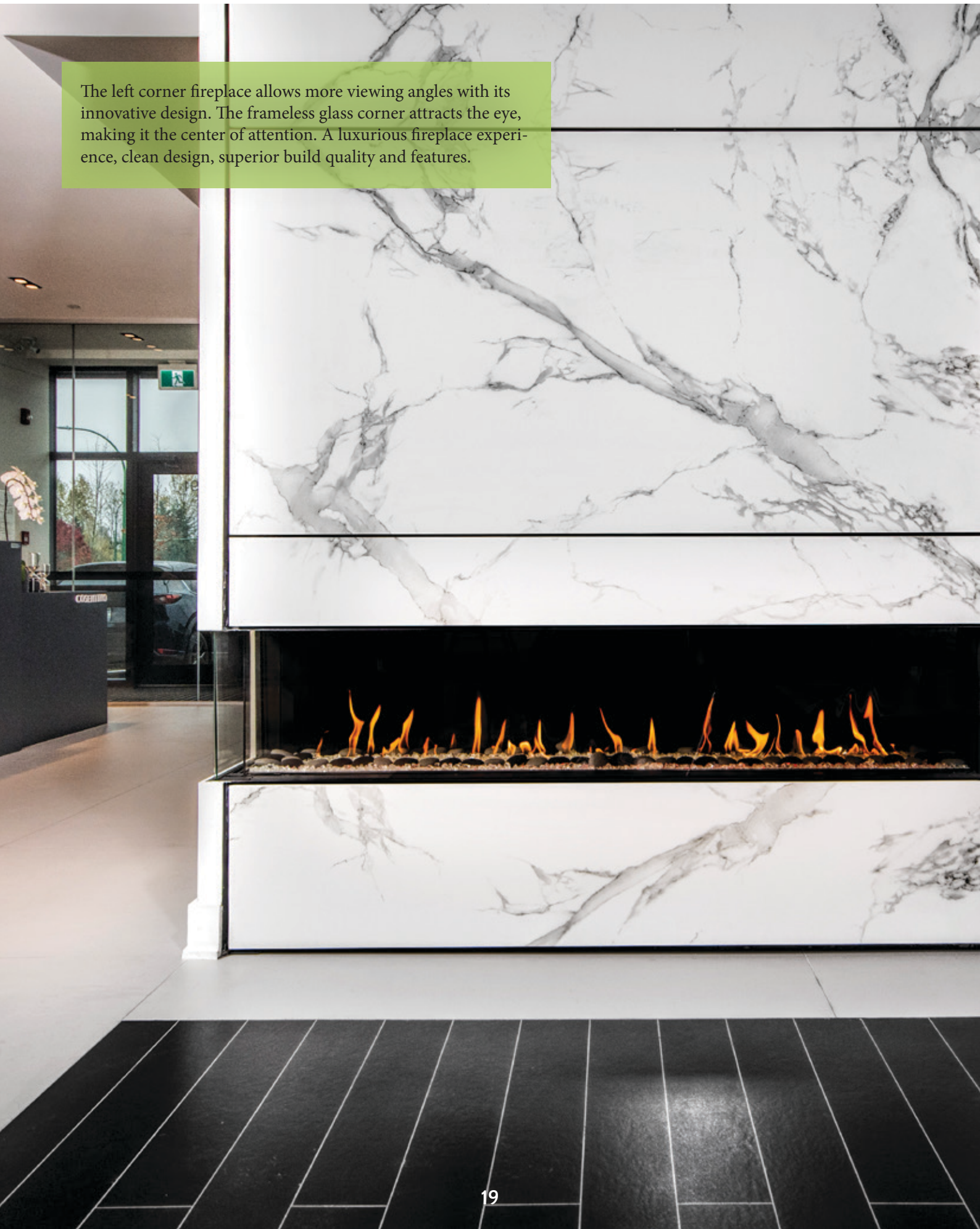

SPECIFICATIONS

Model	BTU/hr (max)	BTU/hr (min)	Efficiency
Flare-LC-30-H	34,000	18,500	79.4 %
Flare-LC-45-R/H/EH	36,800	22,000	79.7 %
Flare-LC-50-R/H/EH	47,000	22,750	79.8 %
Flare-LC-60-R/H/EH	50,000	28,000	79.8 %
Flare-LC-70-R/H/EH	52,200	28,000	79.9 %
Flare-LC-80-R/H/EH	55,700	31,000	80.2 %
Flare-LC-100-R/H/EH	60,000	32,500	80.5 %

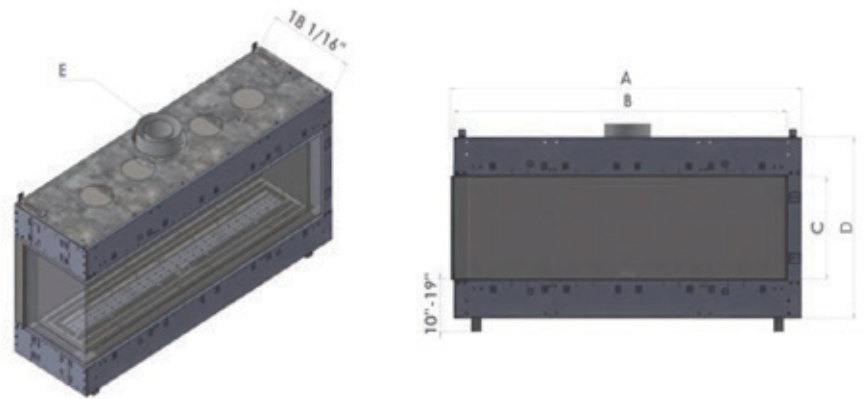

A: Full Width B: Opening Width C: Opening Height
 D: Fireplace Height, Minus Legs E: Vent Pipe Diameter

Model	A	B	C	D	E
Flare-LC-45	43 9/16	41 1/16	16	28	4x6
Flare-LC-50	50 4/16	47 13/16	16	28	5x8
Flare-LC-60	60 1/16	57 10/16	16	28	5x8
Flare-LC-70	69 15/16	67 8/16	16	28	5x8
Flare-LC-80	82 8/16	80 1/16	16	28	5x8
Flare-LC-100	99 7/16	97	16	28	5x8
*Flare-LC-30-H	30 9/16	28 8/16	24	35 14/16	4x6
Flare-LC-45-H	43 9/16	41 1/16	24	35 14/16	4x6
Flare-LC-50-H	50 4/16	47 13/16	24	35 14/16	5x8
Flare-LC-60-H	60 1/16	57 10/16	24	35 14/16	5x8
Flare-LC-70-H	69 15/16	67 8/16	24	35 14/16	5x8
Flare-LC-80-H	82 8/16	80 1/16	24	35 14/16	5x8
Flare-LC-100-H	99 7/16	97	24	35 14/16	5x8
Flare-LC-45-EH	43 9/16	41 1/16	30	42 3/16	5x8
Flare-LC-50-EH	50 4/16	47 13/16	30	42 3/16	5x8
Flare-LC-60-EH	60 1/16	57 10/16	30	42 3/16	5x8
Flare-LC-70-EH	69 15/16	67 8/16	30	42 3/16	5x8
Flare-LC-80-EH	82 8/16	80 1/16	30	42 3/16	5x8
Flare-LC-100-EH	99 7/16	97	30	42 3/16	5x8

*Flare-LC-30-H is only available in 24" glass height

DOUBLE CORNER

An intriguing three-sided view of the fireplace makes the Flare Double Corner exceptionally stylish and practical. The fireplace corners are clean and smooth thanks to Flare's glass to glass technology.



SPECIFICATIONS



Model	BTU/hr (max)	BTU/hr (min)	Efficiency
Flare-DC-30-H	34,000	18,500	79.4 %
Flare-DC-45-R/H/EH	36,800	22,000	79.7 %
Flare-DC-50-R/H/EH	47,000	22,750	79.8 %
Flare-DC-60-R/H/EH	50,000	28,000	79.8 %
Flare-DC-70-R/H/EH	52,200	28,000	79.9 %
Flare-DC-80-R/H/EH	55,700	31,000	80.2 %
Flare-DC-100-R/H/EH	60,000	32,500	80.5 %

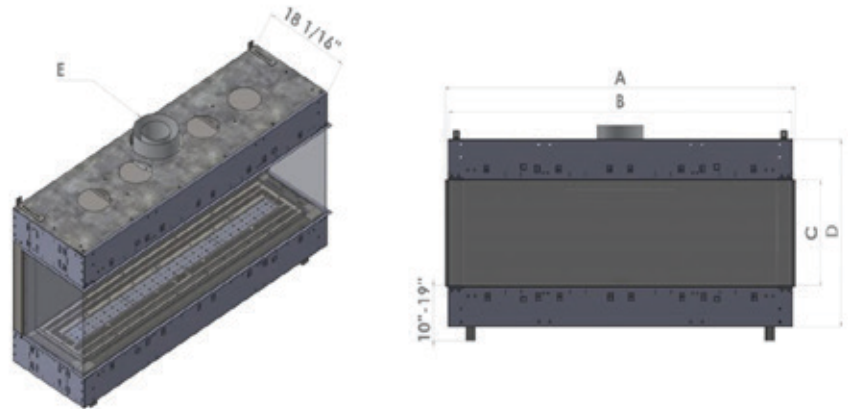

A: Full Width B: Opening Width C: Opening Height
 D: Fireplace Height, Minus Legs E: Vent Pipe Diameter

Model	A	B	C	D	E
Flare-DC-45	43 9/16	43 7/16	16	28	4x6
Flare-DC-50	50 4/16	50 2/16	16	28	5x8
Flare-DC-60	60 2/16	59 15/16	16	28	5x8
Flare-DC-70	69 15/16	69 13/16	16	28	5x8
Flare-DC-80	82 9/16	82 6/16	16	28	5x8
Flare-DC-100	99 8/16	99 5/16	16	28	5x8
*Flare-DC-30-H	30 9/16	30 7/16	24	35 14/16	4x6
Flare-DC-45-H	43 9/16	43 7/16	24	35 14/16	4x6
Flare-DC-50-H	50 4/16	50 2/16	24	35 14/16	5x8
Flare-DC-60-H	60 2/16	59 15/16	24	35 14/16	5x8
Flare-DC-70-H	69 15/16	69 13/16	24	35 14/16	5x8
Flare-DC-80-H	82 9/16	82 6/16	24	35 14/16	5x8
Flare-DC-100-H	99 8/16	99 5/16	24	35 14/16	5x8
Flare-DC-45-EH	43 9/16	43 7/16	30	42 3/16	5x8
Flare-DC-50-EH	50 4/16	50 2/16	30	42 3/16	5x8
Flare-DC-60-EH	60 2/16	59 15/16	30	42 3/16	5x8
Flare-DC-70-EH	69 15/16	69 13/16	30	42 3/16	5x8
Flare-DC-80-EH	82 9/16	82 6/16	30	42 3/16	5x8
Flare-DC-100-EH	99 8/16	99 5/16	30	42 3/16	5x8

*Flare-DC-30-H is only available in 24" glass height

ROOM DEFINER

A stunning peninsula design with a side vent, intended as a room divider. The three glass sides creates an impressive and magnificent way to give character to any living area. The design possibilities are endless.



SPECIFICATIONS



Model	BTU/hr (max)	BTU/hr (min)	Efficiency
Flare-RD-45-R/H/EH	36,800	22,000	79.4 %
Flare-RD-50-R/H/EH	47,000	22,750	79.5
Flare-RD-60-R/H/EH	50,000	28,000	79.5
Flare-RD-70-R/H/EH	52,200	28,000	79.8
Flare-RD-80-R/H/EH	55,700	31,000	80.1
Flare-RD-100-R/H/EH	60,000	32,500	80.4

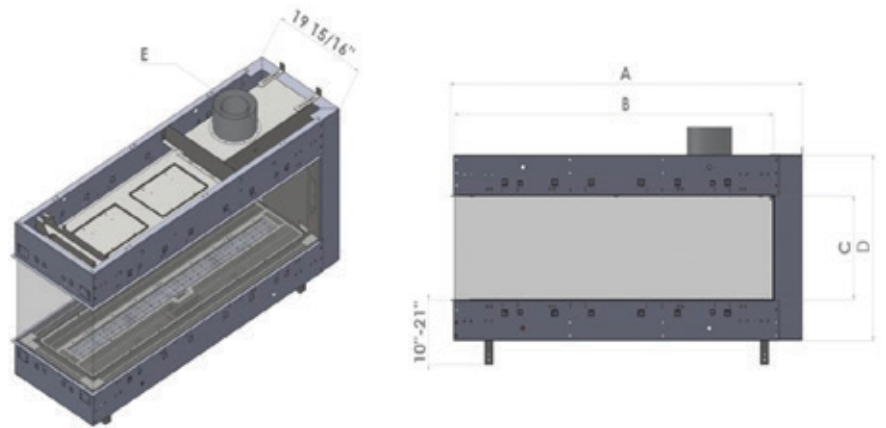

A: Full Width B: Opening Width C: Opening Height
 D: Fireplace Height, Minus Legs E: Vent Pipe Diameter

Model	A	B	C	D	E
Flare-RD-45	46 15/16	41	16	28 12/16	5x8
Flare-RD-50	53	47 11/16	16	28 12/16	5x8
Flare-RD-60	62 13/16	57 9/16	16	28 12/16	5x8
Flare-RD-70	72 11/16	67 6/16	16	28 12/16	5x8
Flare-RD-80	85 4/16	80	16	28 12/16	5x8
Flare-RD-100	102 3/16	96 15/16	16	28 12/16	5x8
Flare-RD-45-H	46 15/16	41	24	36 10/16	5x8
Flare-RD-50-H	53	47 11/16	24	36 10/16	5x8
Flare-RD-60-H	62 13/16	57 9/16	24	36 10/16	5x8
Flare-RD-70-H	72 11/16	67 6/16	24	36 10/16	5x8
Flare-RD-80-H	85 4/16	80	24	36 10/16	5x8
Flare-RD-100-H	102 3/16	96 15/16	24	36 10/16	5x8
Flare-RD-45-EH	46 15/16	41	30	42 7/8	5x8
Flare-RD-50-EH	53	47 11/16	30	42 7/8	5x8
Flare-RD-60-EH	62 13/16	57 9/16	30	42 7/8	5x8
Flare-RD-70-EH	72 11/16	67 6/16	30	42 7/8	5x8
Flare-RD-80-EH	85 4/16	80	30	42 7/8	5x8
Flare-RD-100-EH	102 3/16	96 15/16	30	42 7/8	5x8

PASSAGE FRONT & SEE THRU

Flare's Passage Front and See-Through fireplace offers a vertical design, intended to offer a modern twist on the linear design Flare is known for. The 60" tall glass face creates an impressive visual experience, designed to give a new perspective on what a modern fireplace can be.

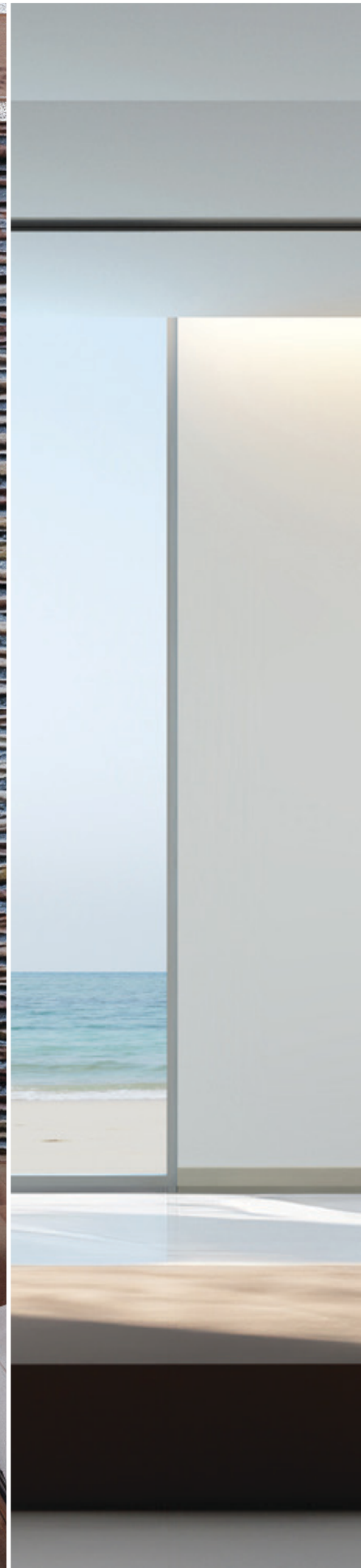

*The Flare Passage See-Through Fireplace can be ordered as an indoor/outdoor application using the Flare Outdoor Kit.

ROUGH



SPECIFICATIONS

Model	BTU/hr (max)	BTU/hr (min)	Efficiency
PAS-FF-30-EH	34,000	26,200	80.4 %
PAS-ST-30-EH	34,000	26,200	80.4 %

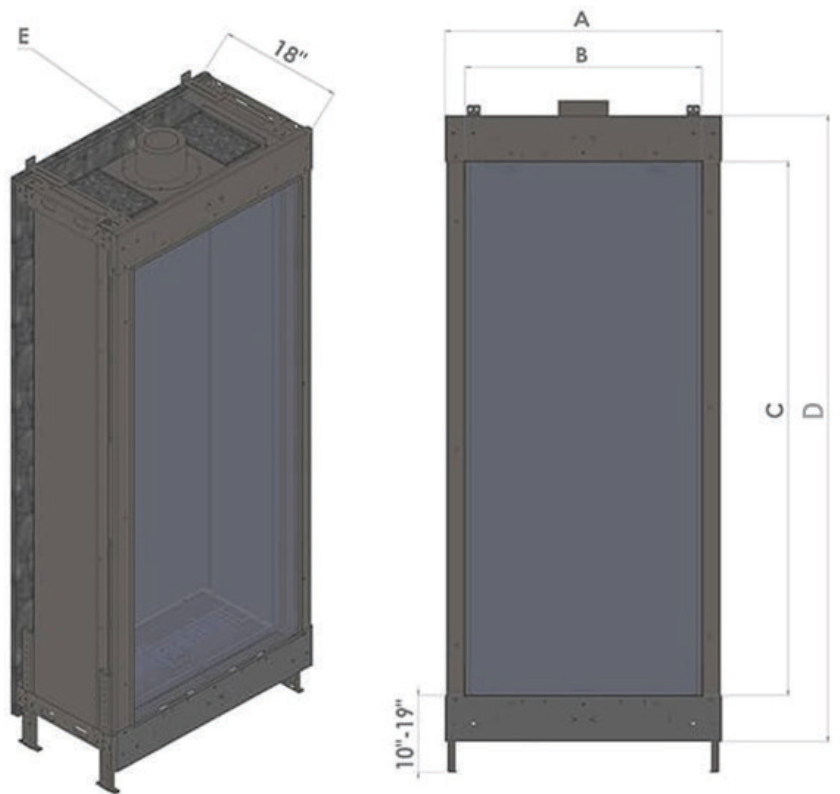

Model	A	B	C	D	E
PASS-FF-30-EH	30	28	60	82	5x8
PASS-ST-30-EH	30	28	60	82	5x8

TRADITIONAL

Our traditional direct vent fireplace with a modern look is the perfect addition to any home or business. With a sleek and contemporary design, it will seamlessly blend into any décor while providing a warm and cozy atmosphere. The direct vent system ensures safe and efficient operation, while the realistic flames and stone background create an inviting ambiance that will make you never want to leave the comfort of your own home.



SPECIFICATIONS



Model	BTU/hr (max)	BTU/hr (min)	Efficiency
DV-TRA-42	37,000	28,000	80
DV-TRA-46	37,000	28,000	80

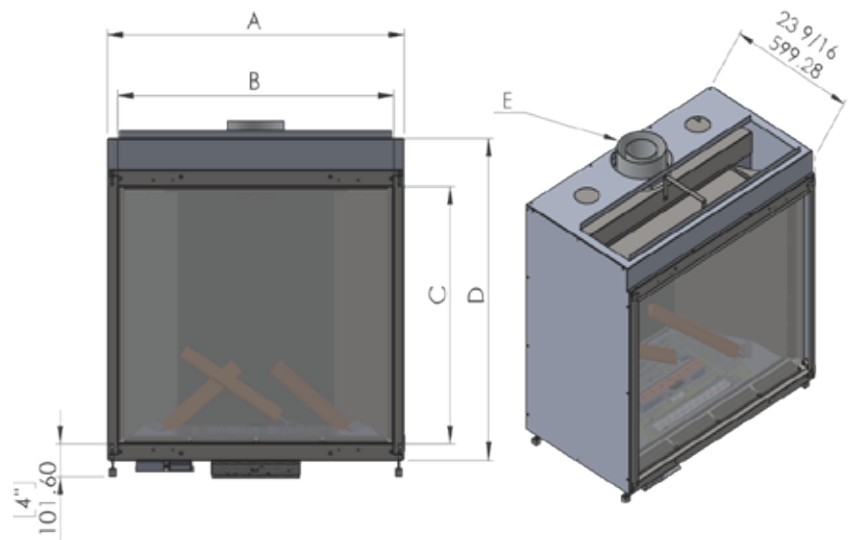

Model	A	B	C	D	E
DV-TRA-42	42 1/4	38 11/16	32 1/16	41 3/8	5x8
DV-TRA-46	46	42 7/16	36	45 5/16	5x8



PICTURE KEY

COVER

See Through 70

PAGE 1

Double Corner 80 Screened

PAGE 3

Room Definer 70

Double Corner 60

Room Definer 45 Screened

PAGE 4

Left Corner 100 High

Front Facing 80

PAGE 5

Double Corner 60

PAGE 6

Front Facing 100

PAGE 8

See Through 100 H Indoor/Outdoor

PAGE 10

See-Through 100 H Indoor/Outdoor

PAGE 13

Front Facing 80 High

PAGE 15

See Through 100

PAGE 17

Right Corner 70 High Screened

PAGE 19

Left Corner 80 High

PAGE 21

Double Corner 50

PAGE 23

Room Definer 50

PAGE 25

Passage Front & See Through

PAGE 27

Traditional 46

PAGE 30

Room Definer 60

BACK COVER

Room Definer 60 Extra High





Flare Fireplaces LLC
890 N. Dorothy Dr. Suite 900
Richardson, TX 75081

Phone/ Fax: 1-866-639-1590

flarefireplaces.com | Version 8.0



SCAN FOR CONTINUOUS EDUCATION CREDIT