

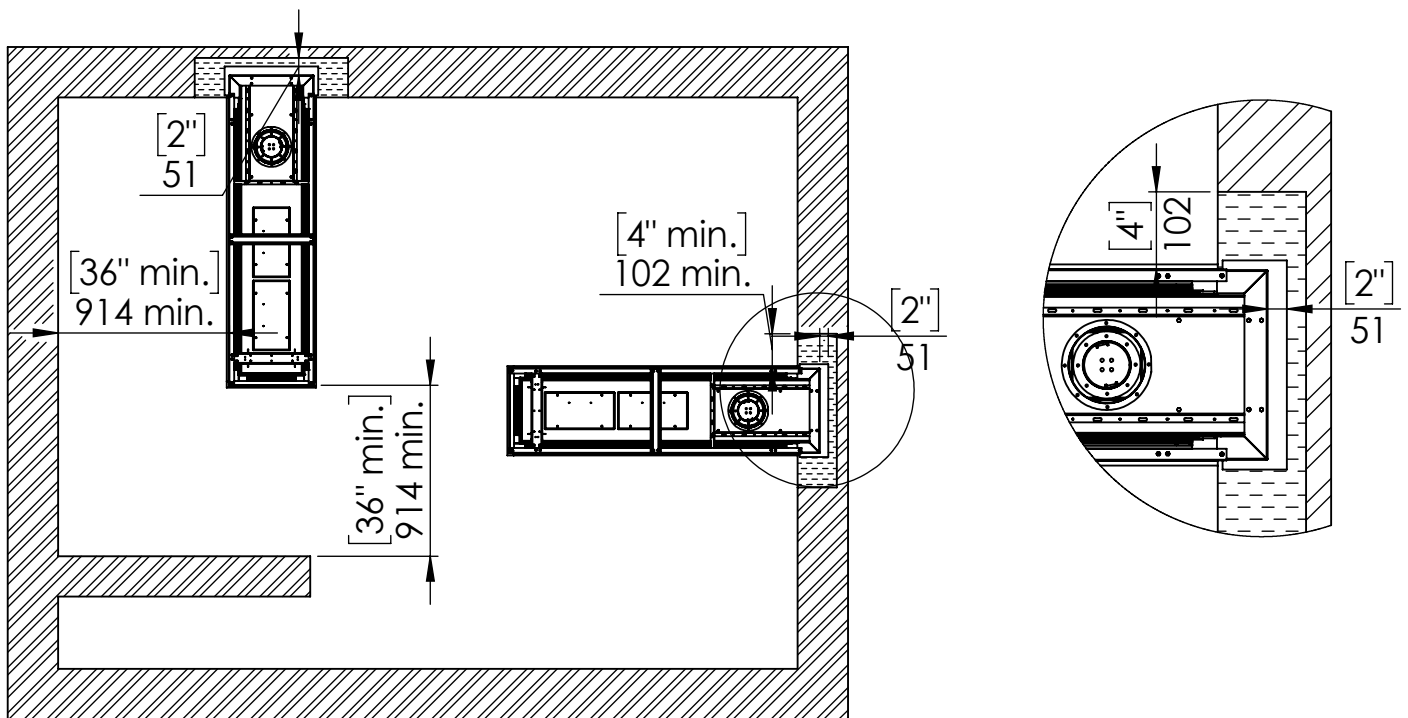

Specifications for Appliance Flare Room Definer 50H

Factor	NG	LPG
Burner Type	105	105
Orifice	1200	320
BTU Max.	47000	35100
BTU min.	22750	18500
Kw/h	13.8k	10.2k
Chimney DIA.	5X8	5X8
Manifold Pressure[w.c]	4.9	10.4
Efficiency rate	78	82
Glass Size Length\Width	1200 X 620 mm	47" 7/16 X 24" 7/16'
Appliance Weigh	155Kg	314lb

Appliance Location



 Combustible Materials
 Non Combustible Materials



Flare Room Definer 50H

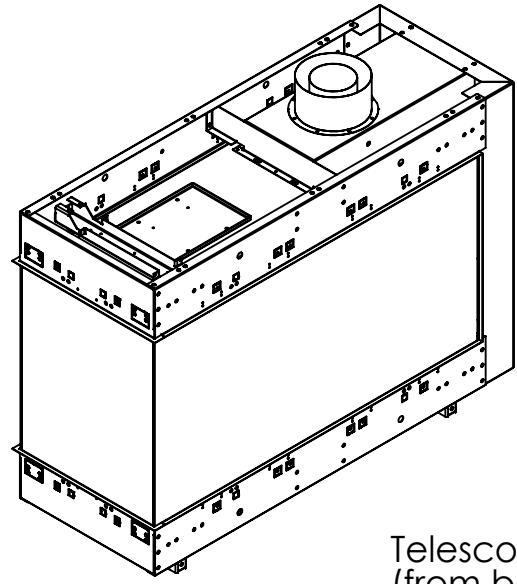
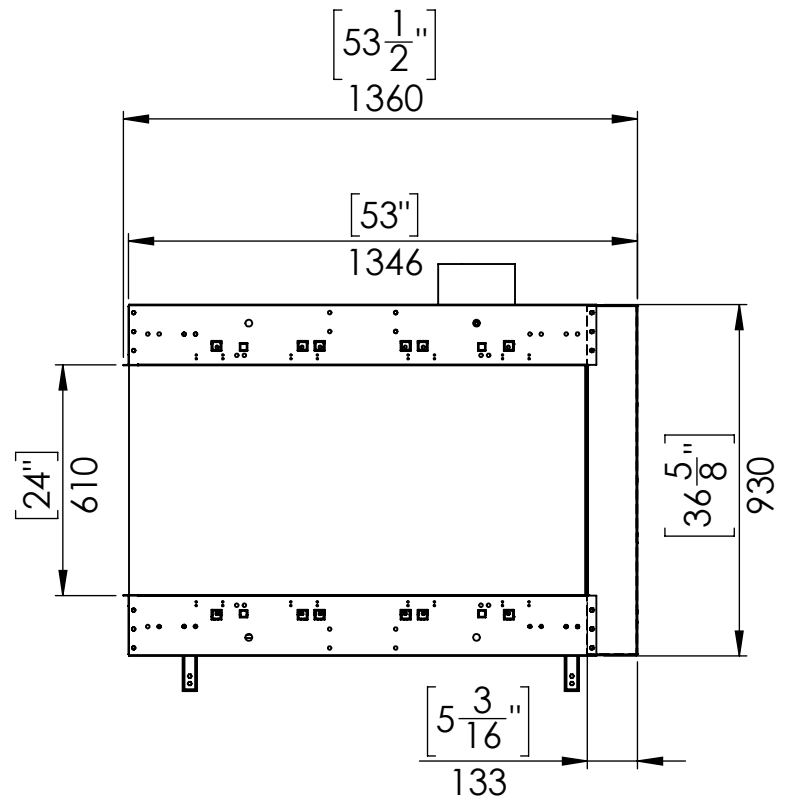
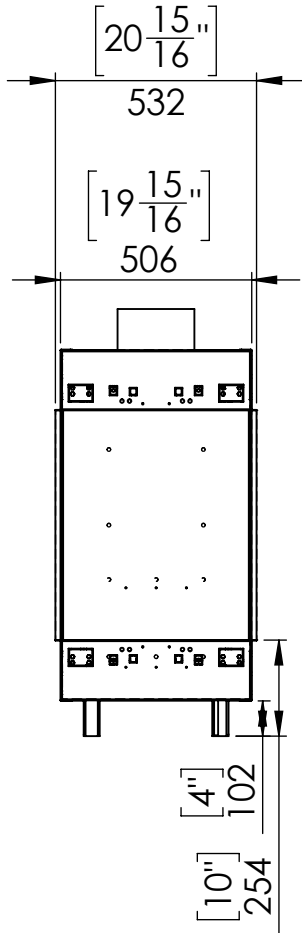
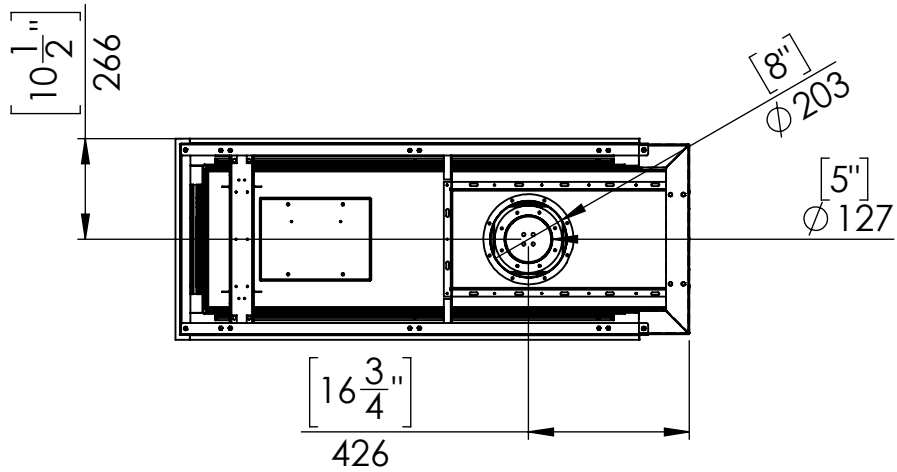

Telescopic leg ranges (from bottom of the glass): 10"-21"

Flat Installation

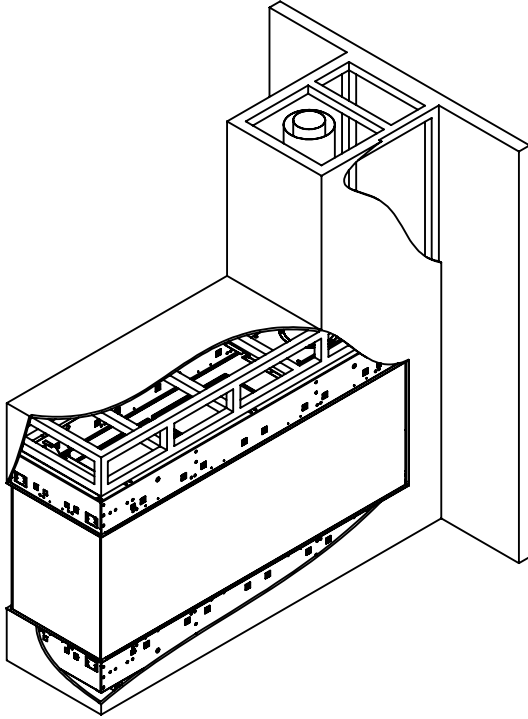

Step 1 - Basic Framing :

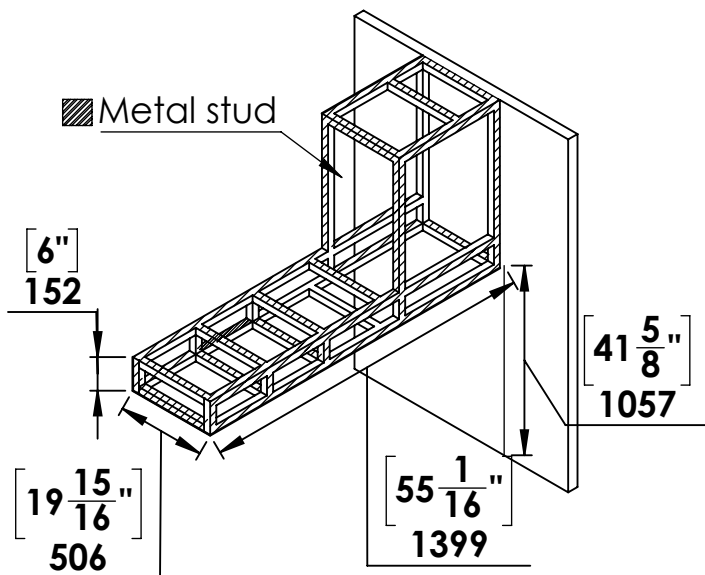

Recess Installation

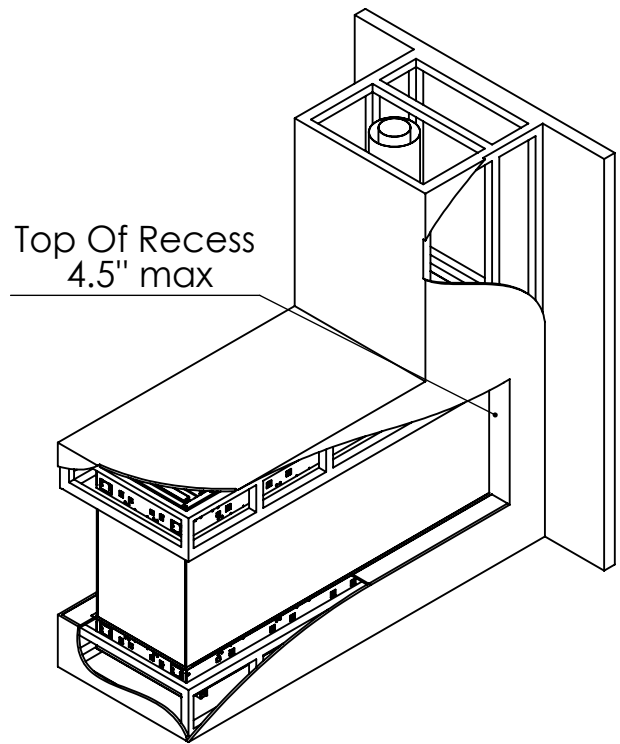

Step 1 - Basic Framing :

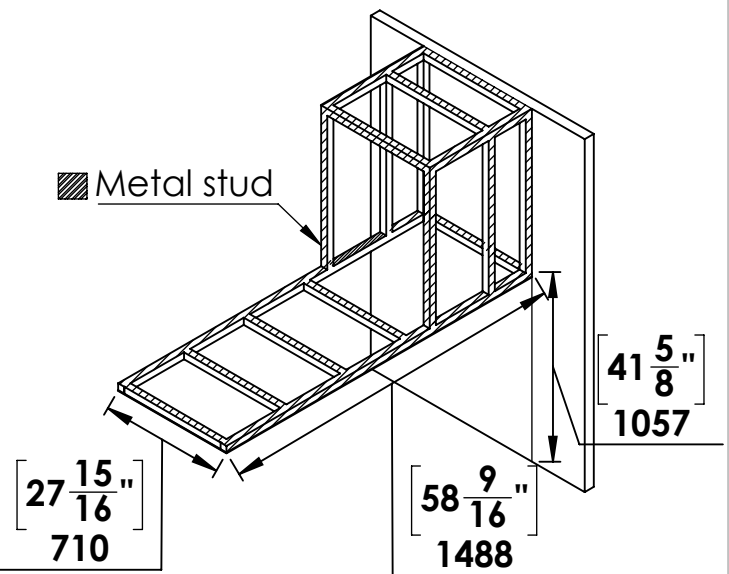

Flat Installation

Step 2 -Positioning the Fireplace:

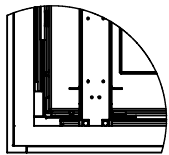
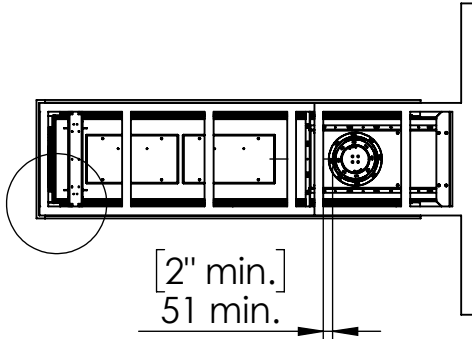

Fireplace frame finishing holder space to match wall finishing thickness

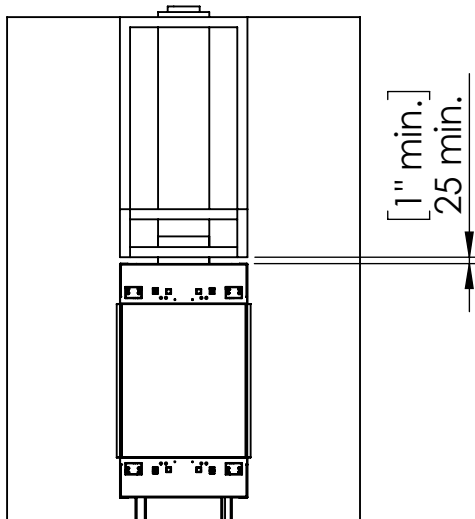

Recess Installation

Step 2 -Positioning the Fireplace:

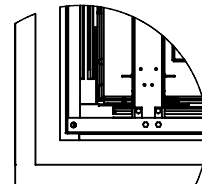
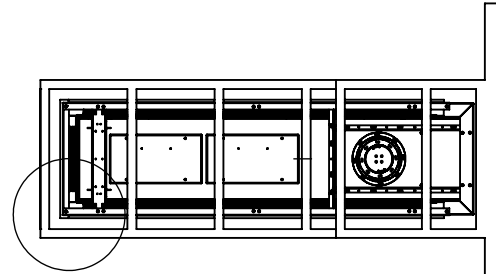

gap to match the max. length of top shelf.

[4" max.]
102 max.

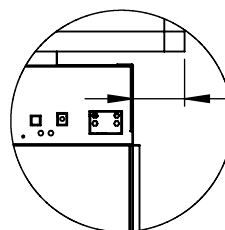
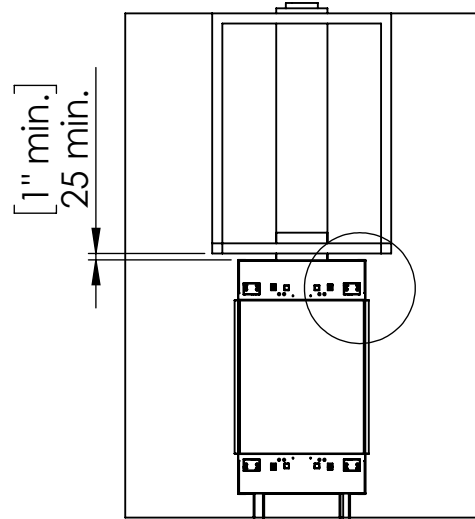

[4" max.]
102 max.

Flat Installation

Last Step - Finishing The Fireplace Wall:

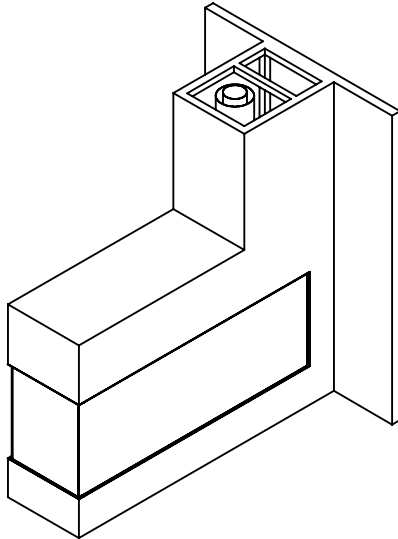

Recess Installation

Step 3 - Framing Front Studs For Recess
After positioning the Fireplace:

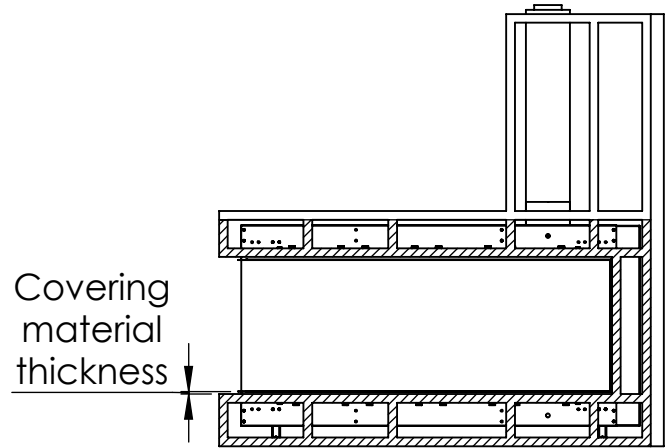

Last Step - Finishing The Fireplace Wall:

