

Flare Front 100 Commercial

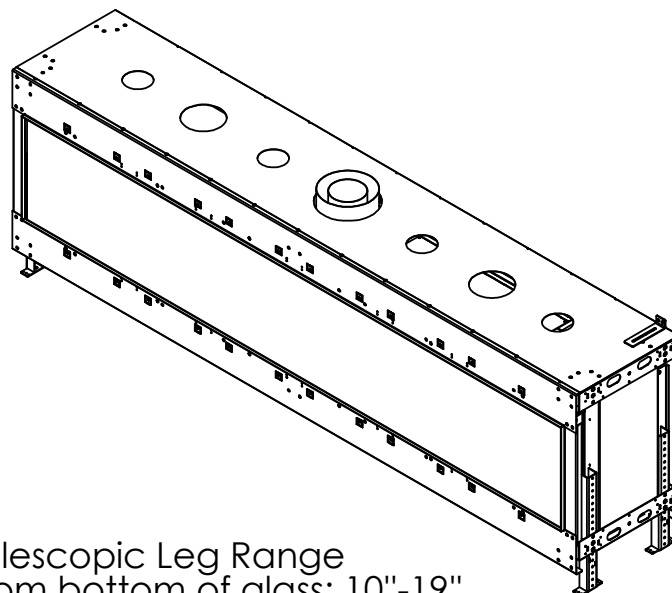

Telescopic Leg Range
From bottom of glass: 10"-19"

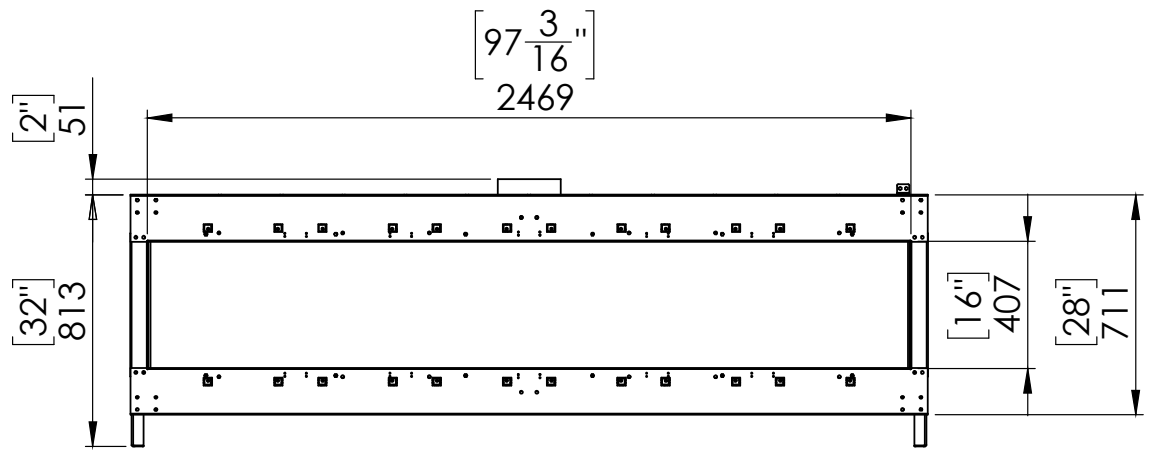
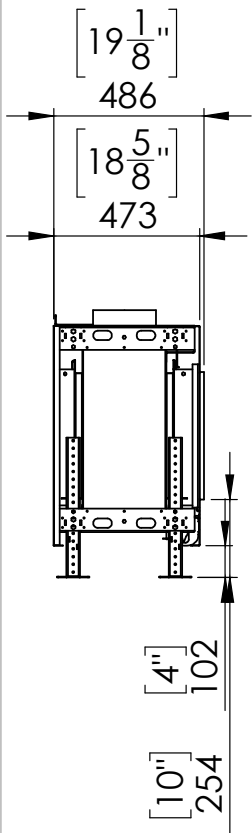
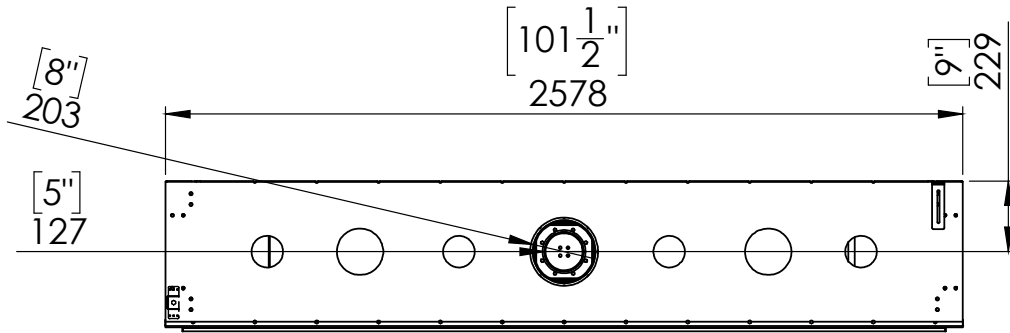
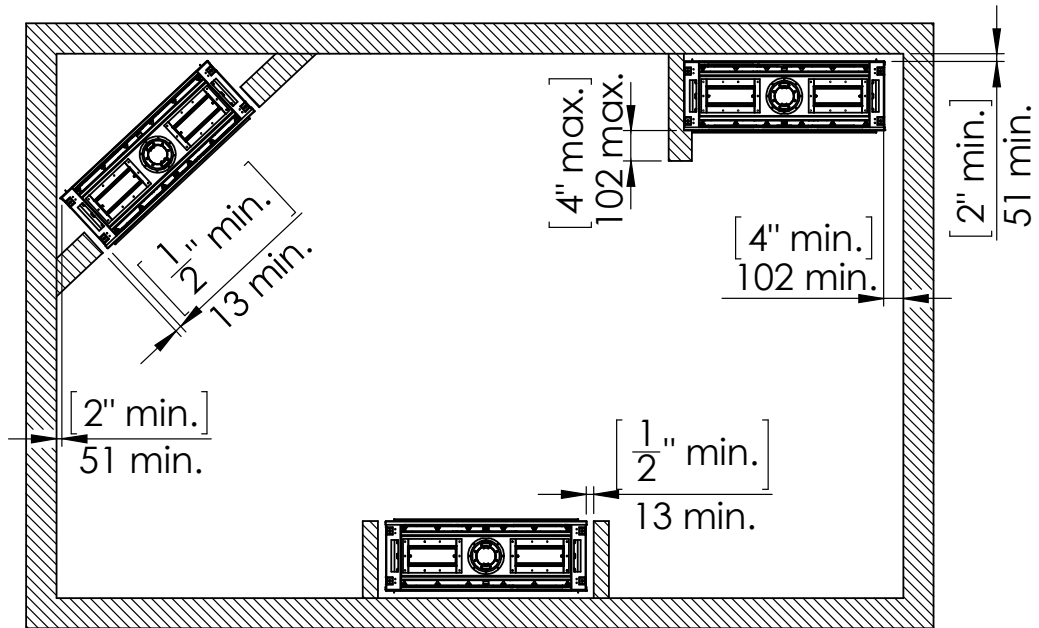

Chimney Installation

Horizontal Termination

For 5 x 8 vent size create 10" x 12" vent termination opening

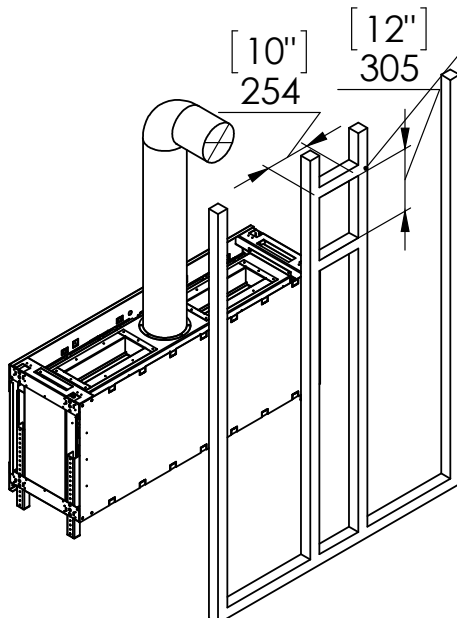

Vertical Termination

For 5 x 8 vent size create 10" x 10" vent termination opening

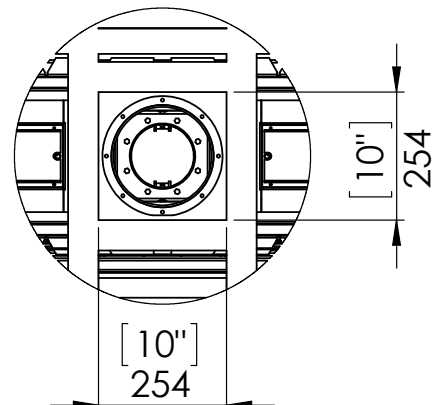
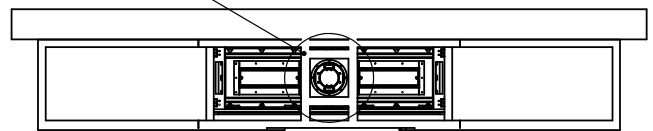

Flat Installation

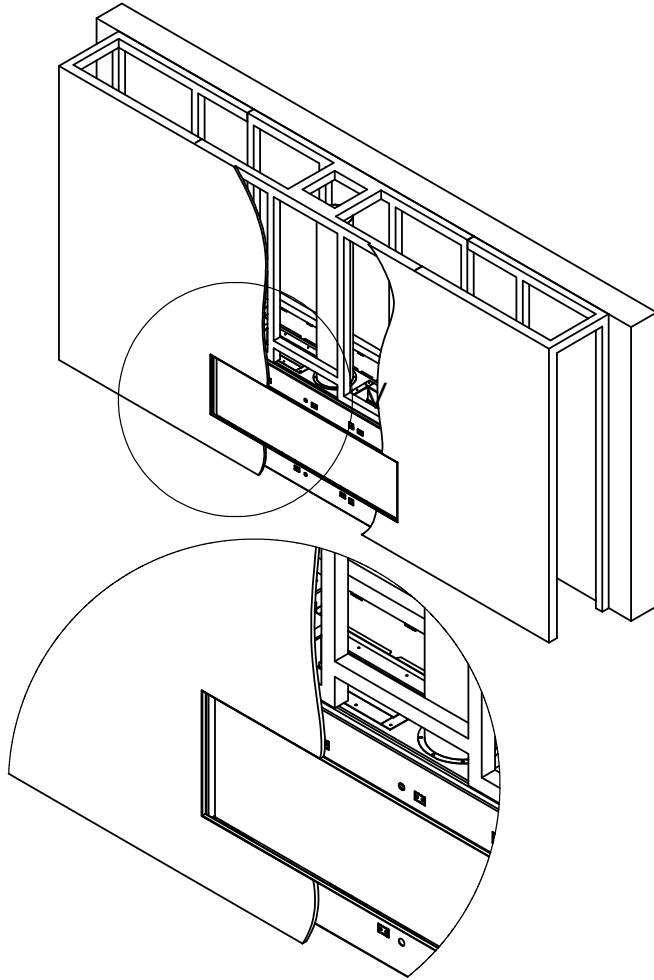

L Shape Installation

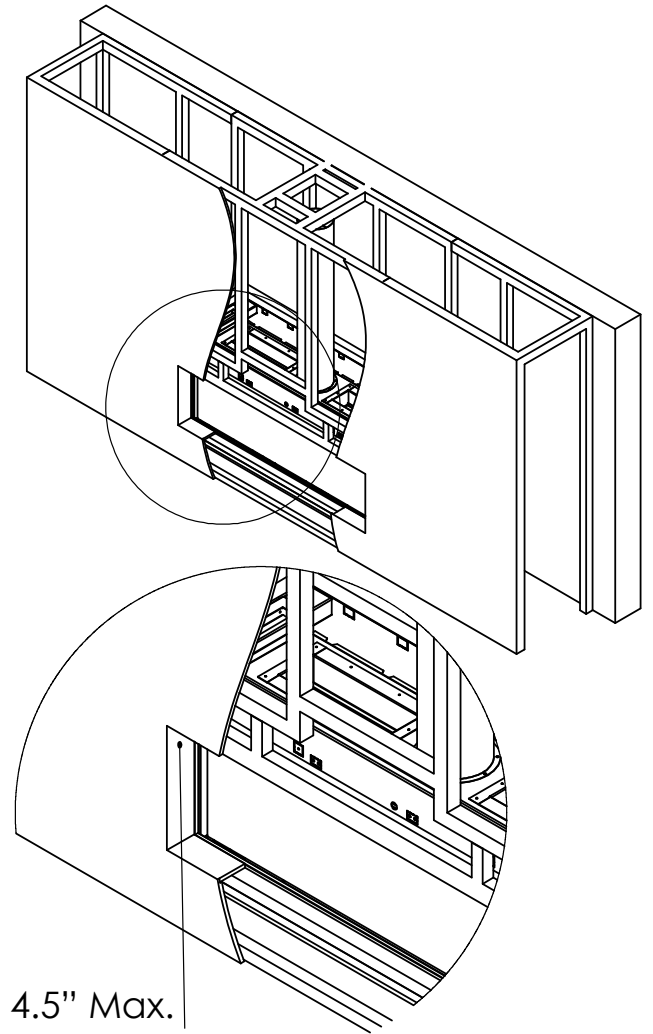

4.5" Max.
Top Of Recess

Step 1 - Basic Framing:

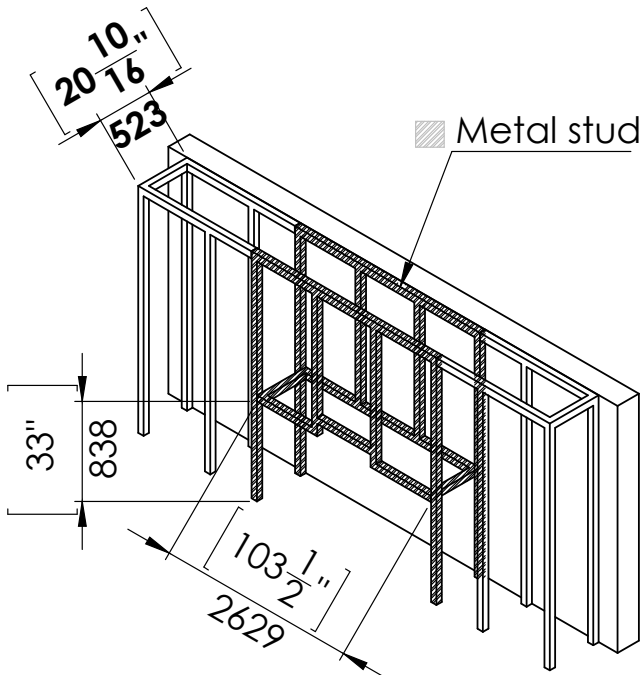

Step 1 - Basic Framing:

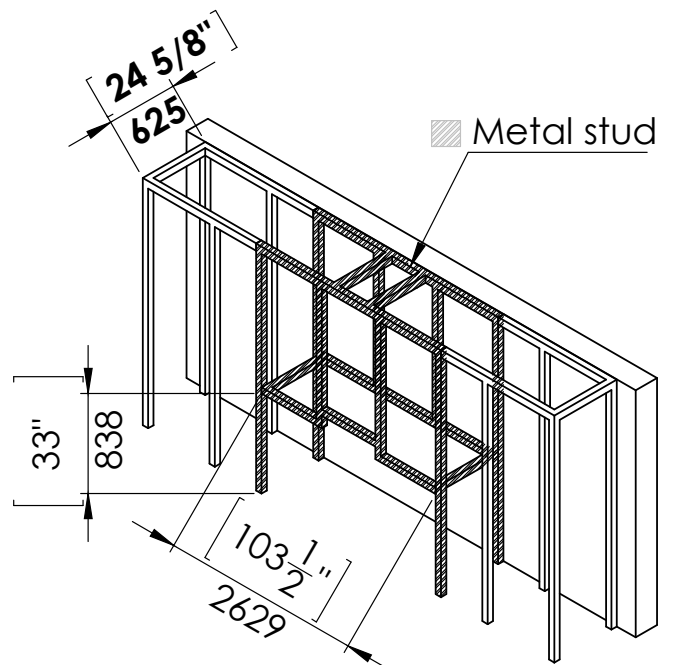

Flat Installation

Step 2 -Positioning the Fireplace:

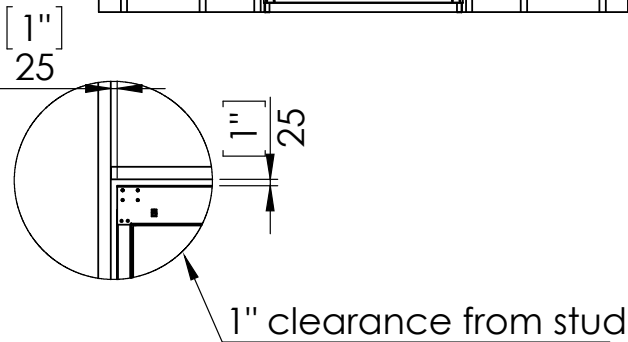
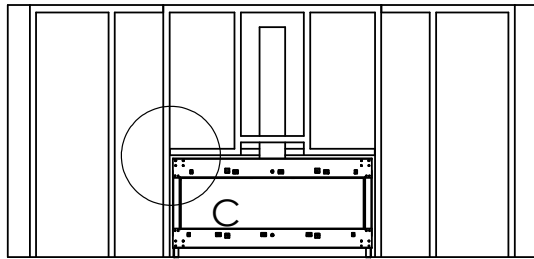
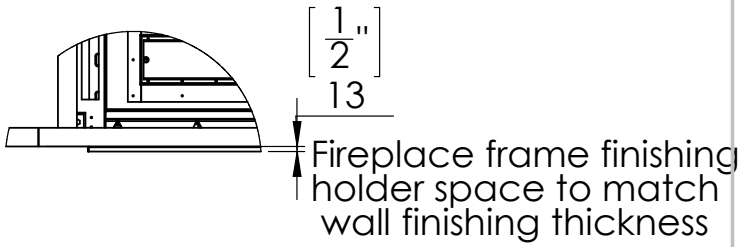
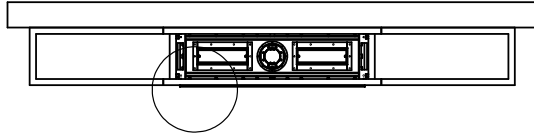

Last Step - Finishing The Fireplace Wall:

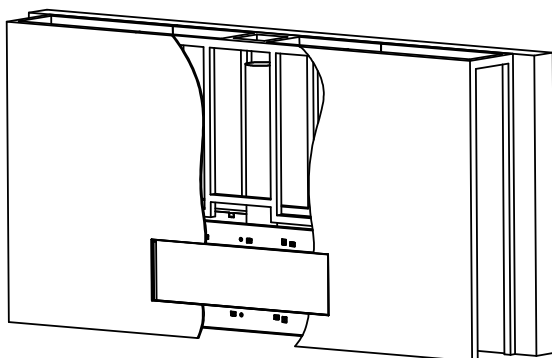

L Shape Installation

Step 2 -Positioning the Fireplace:

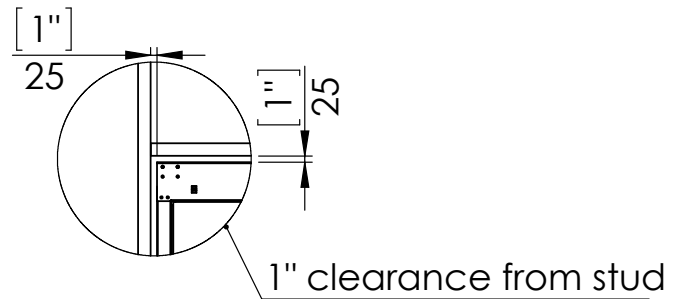
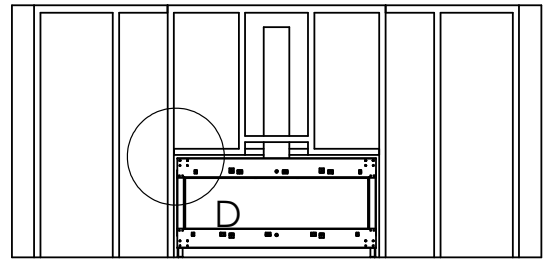
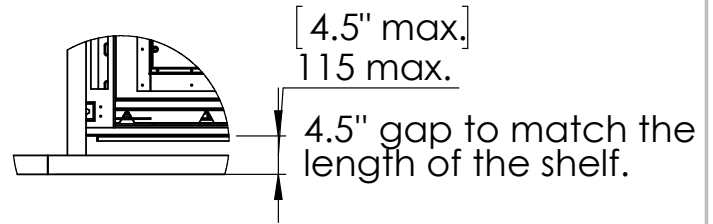
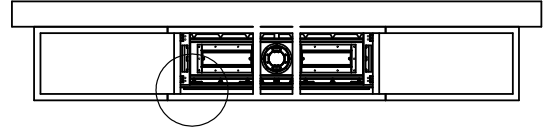

Step 3 - Framing Front Studs For L Shape:

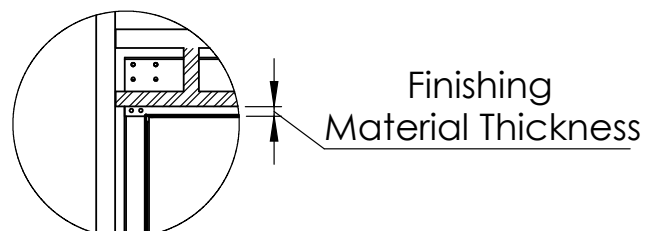
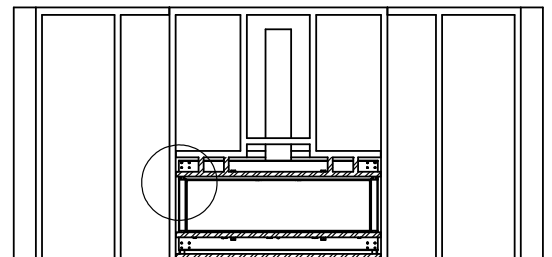

L Shape Finishing Install

Last Step - Finishing The Fireplace Wall:

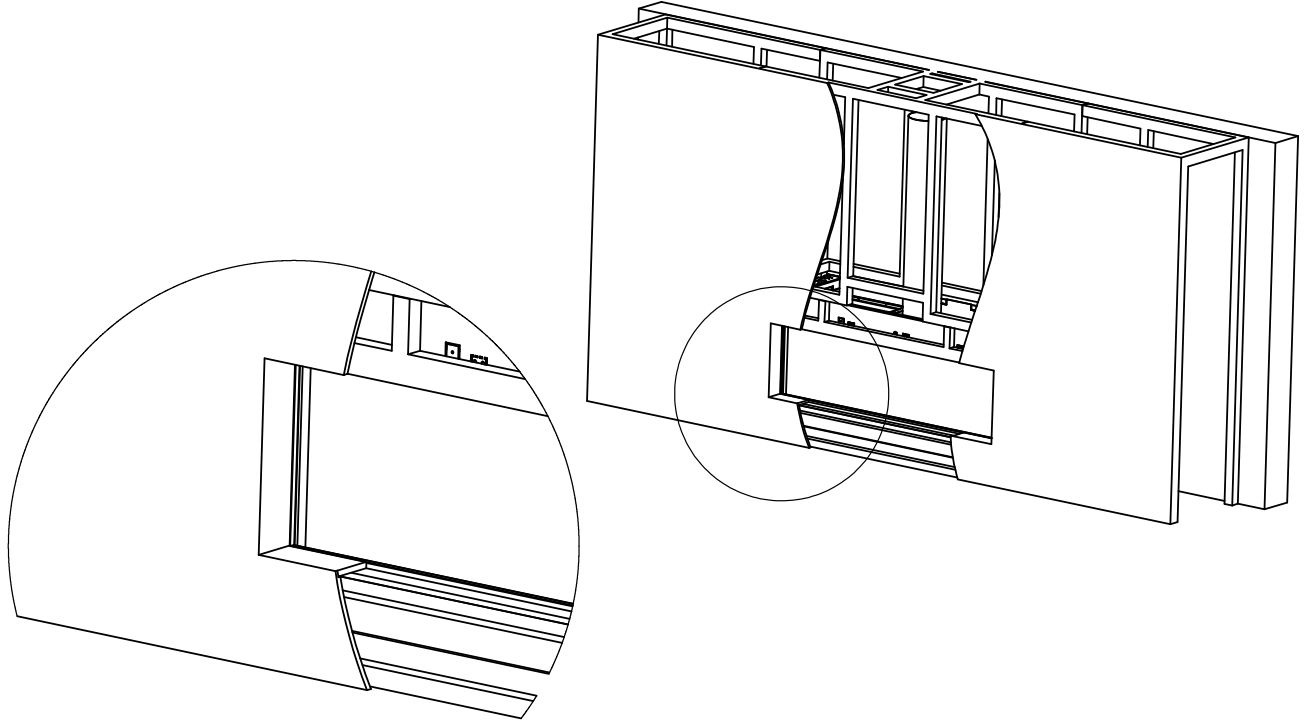

Specifications for Appliance Flare Front 100 Commercial

Factor	NG	LPG
Burner Type	55,105,55	55,105,55
Orifice	550,1200,550	180,260,180
BTU Max.	60000	62000
BTU min.	32500	25500
Kw/h	17.5k	17.5k
Chimney DIA.	5X8	5X8
Manifold Pressure[w.c]	4.0	7.4
Efficiency rate	82	78
Glass Size Length\Width	2455 X 423 mm	96" 10/16 X 16" 9/16'
Appliance Weigh	260Kg	580lb