

# Flare Front 80 Commercial

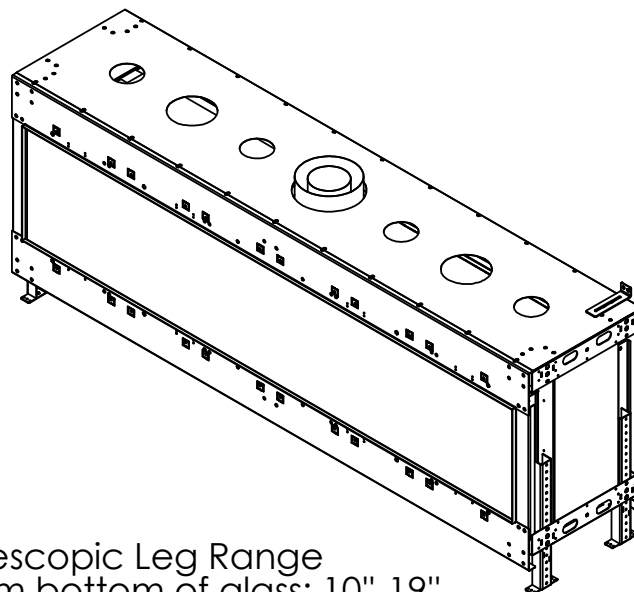

Telescopic Leg Range  
From bottom of glass: 10"-19"

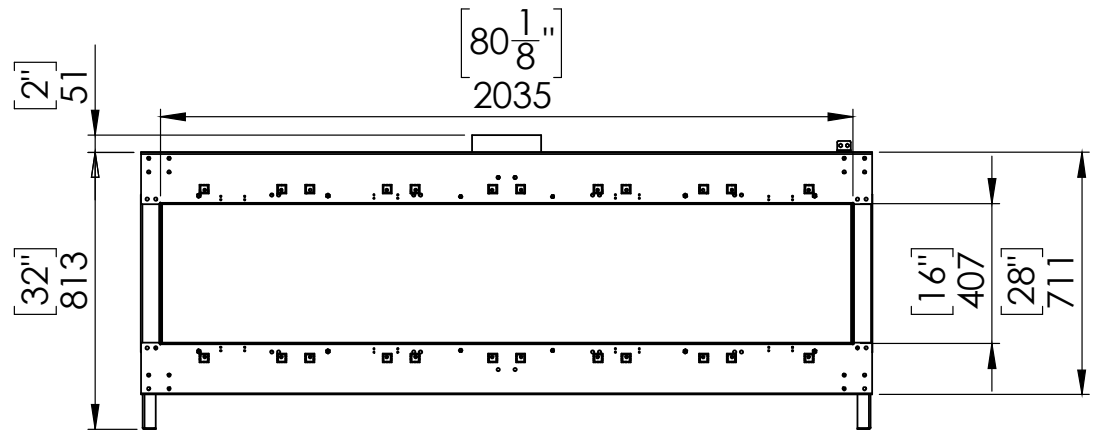
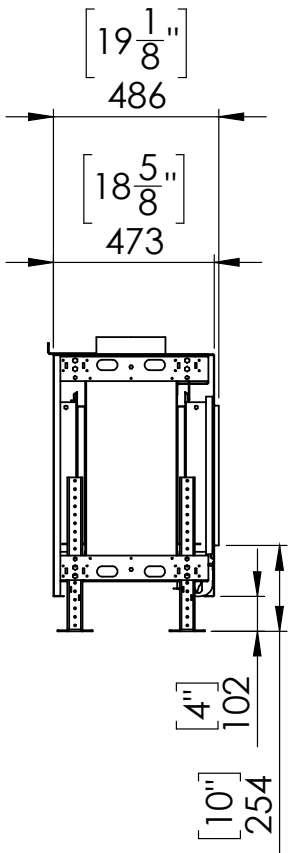
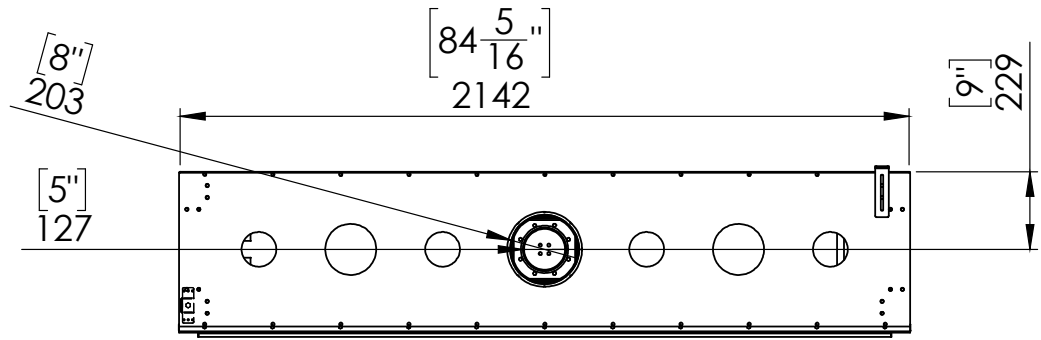
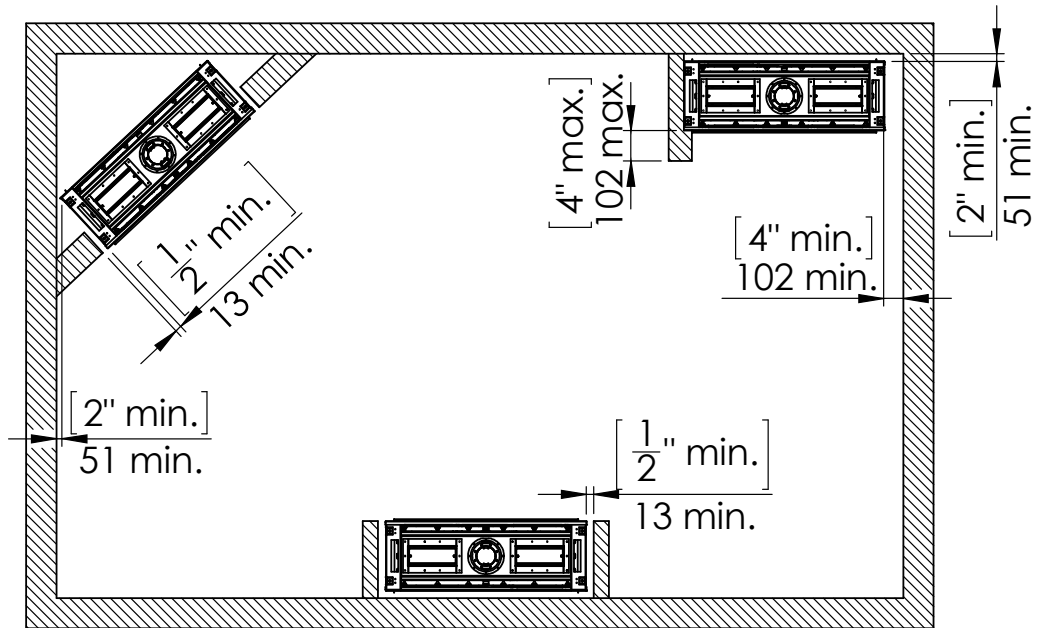

## Chimney Installation

### Horizontal Termination

For 5 x 8 vent size create 10" x 12" vent termination opening

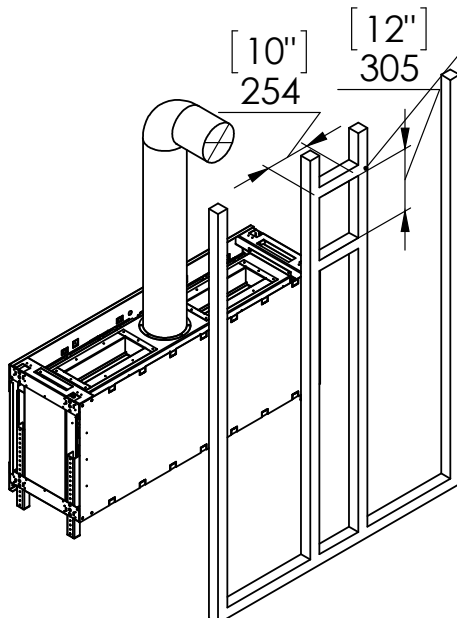

### Vertical Termination

For 5 x 8 vent size create 10" x 10" vent termination opening

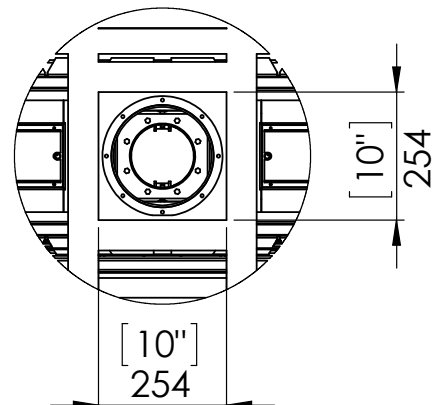
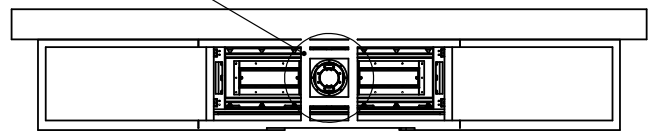

## Flat Installation

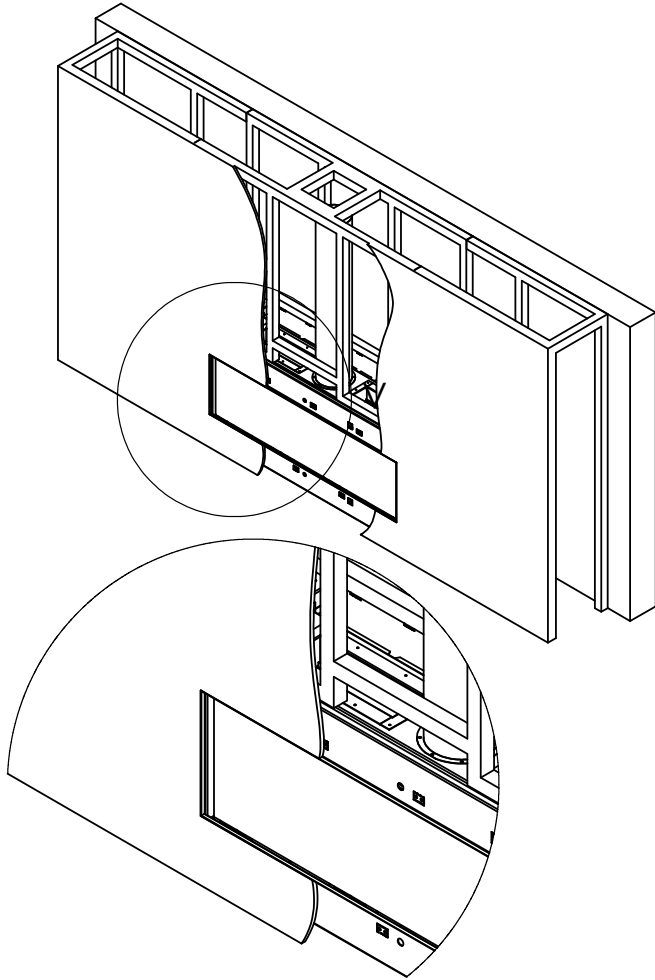

## L Shape Installation

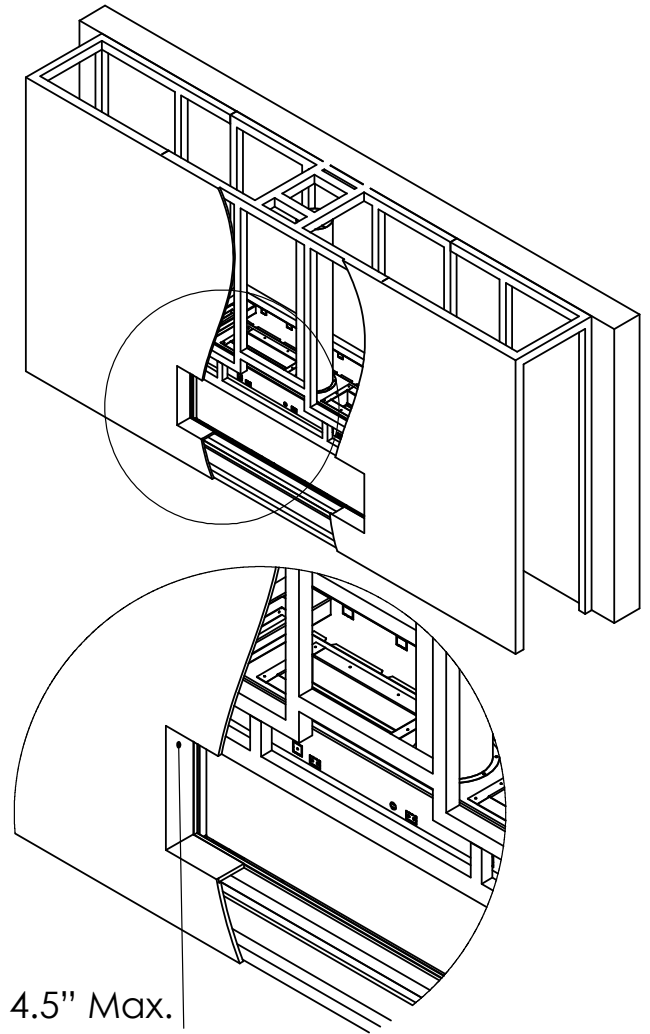

4.5" Max.  
Top Of Recess

### Step 1 - Basic Framing :

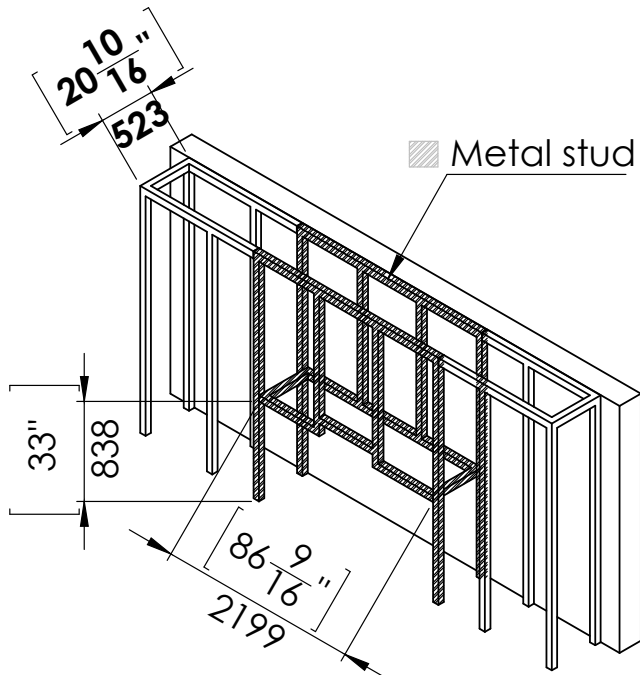

### Step 1 - Basic Framing :

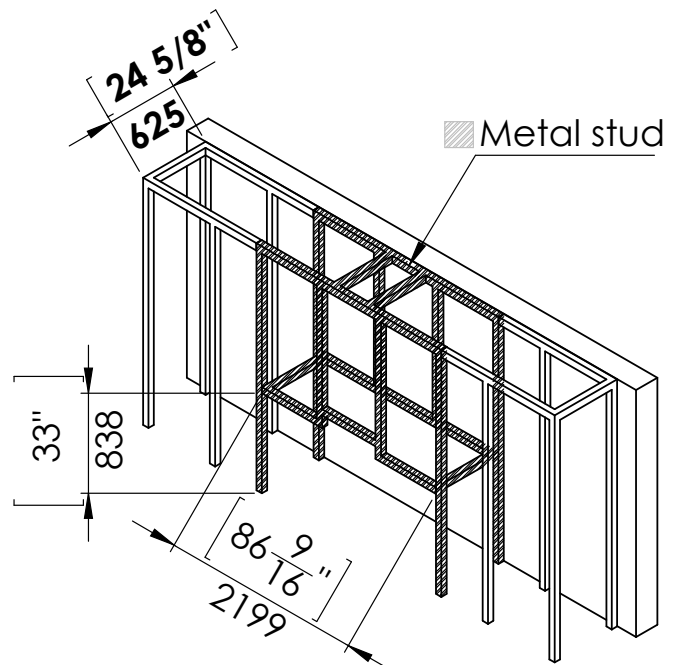

## Flat Installation

Step 2 -Positioning the Fireplace:

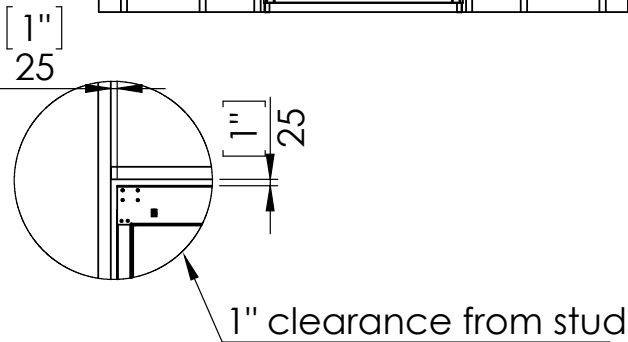
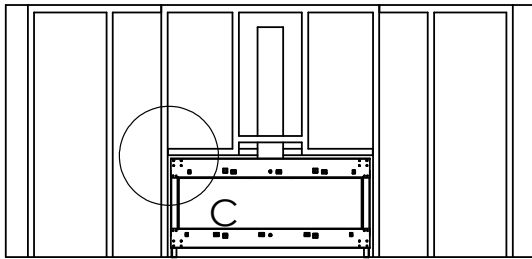
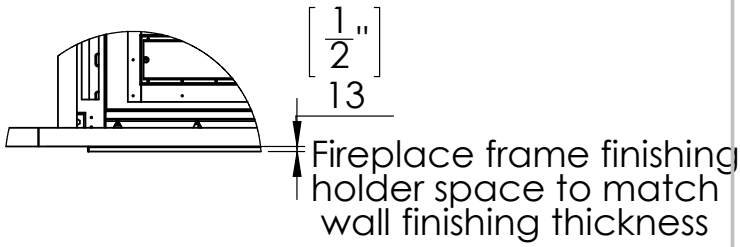
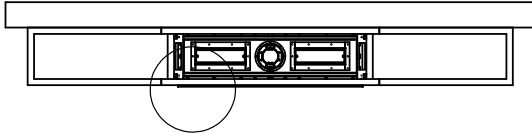

Last Step - Finishing The Fireplace Wall:

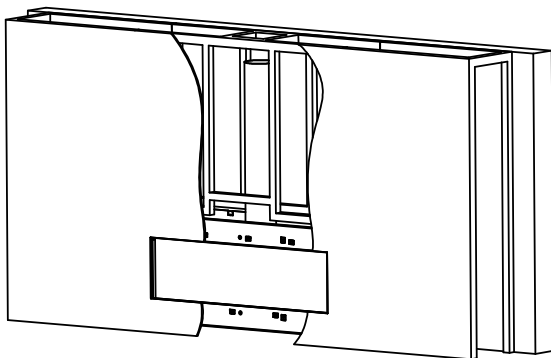

## L Shape Installation

Step 2 -Positioning the Fireplace:

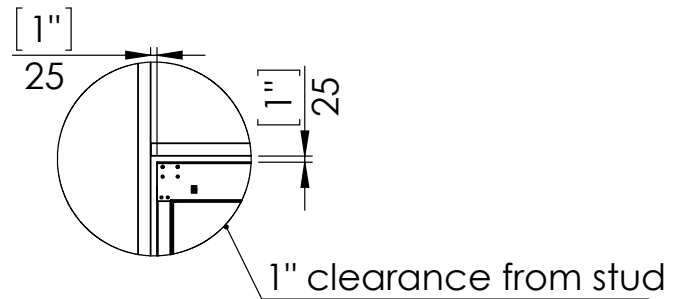
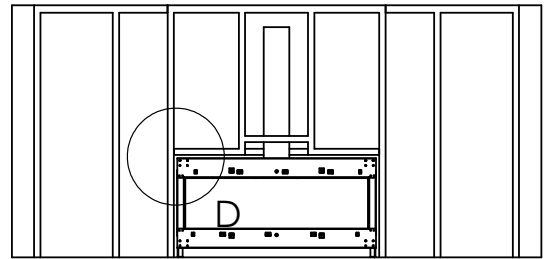
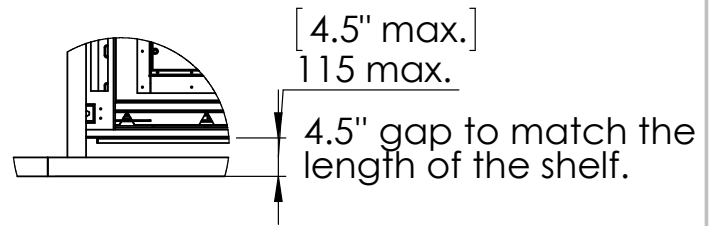
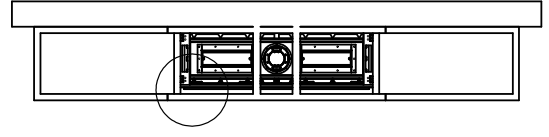

Step 3 - Framing Front Studs For L Shape:

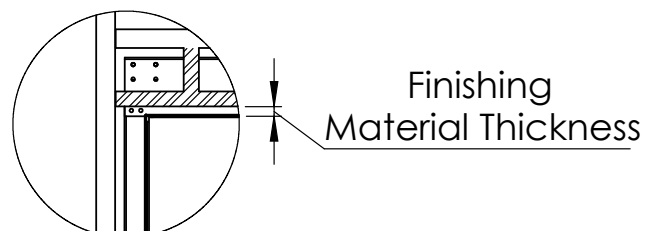
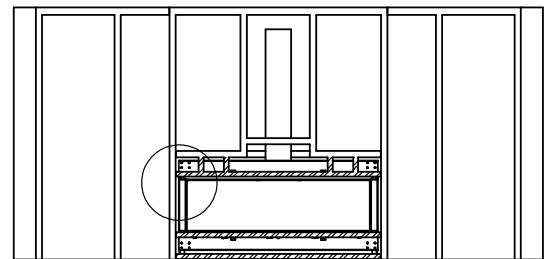

## L Shape Finishing Install

Last Step - Finishing The Fireplace Wall:

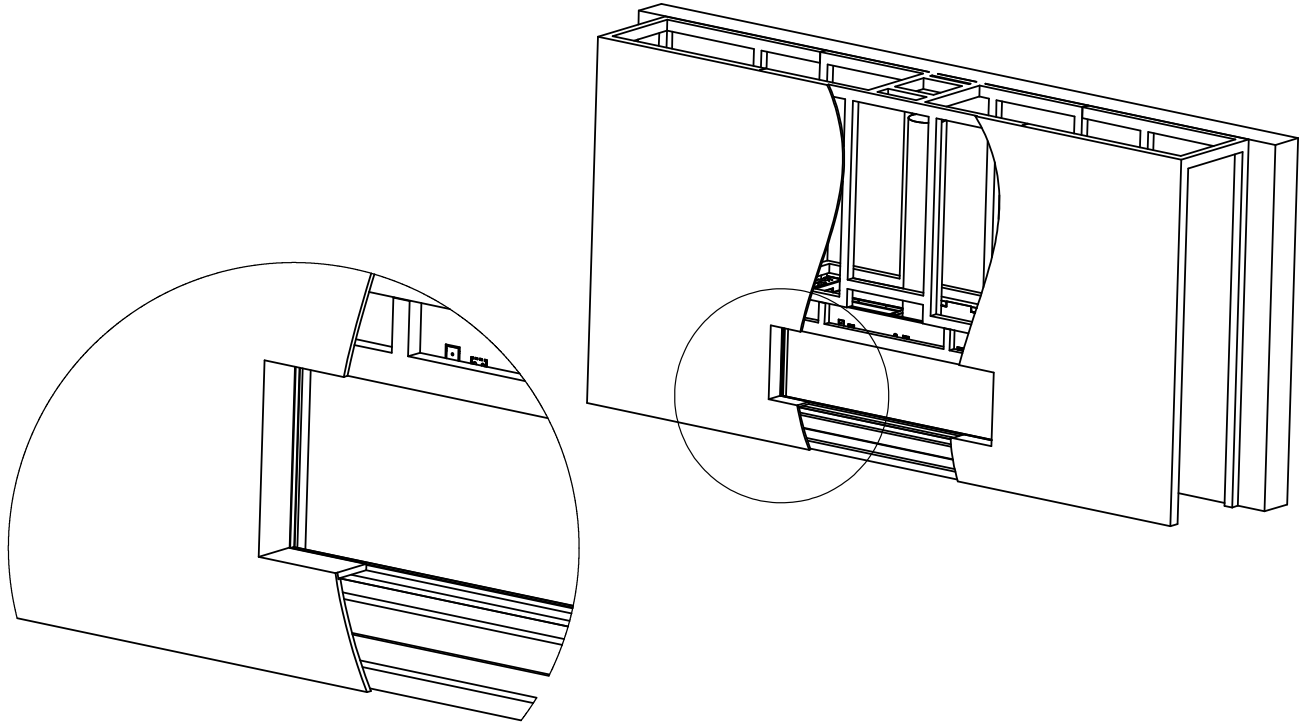

## Specifications for Appliance Flare Front 80 Commercial

Factor	NG	LPG
Burner Type	35,105,35	35,105,35
Orifice	500,1200,500	180,260,180
BTU Max.	55700	46000
BTU min.	31000	20750
Kw/h	16.3k	13.5k
Chimney DIA.	5X8	5X8
Manifold Pressure[w.c]	Screen- 2.6 Double glass -5.4	6.4
Efficiency rate	82	80
Glass Size Length\Width	2025 X 423 mm	79" 3/4 X 16" 11/16'
Appliance Weigh	220Kg	488lb