

Chimney Installation

Horizontal Termination

For 5 x 8 vent size create 10" x 12" vent termination opening

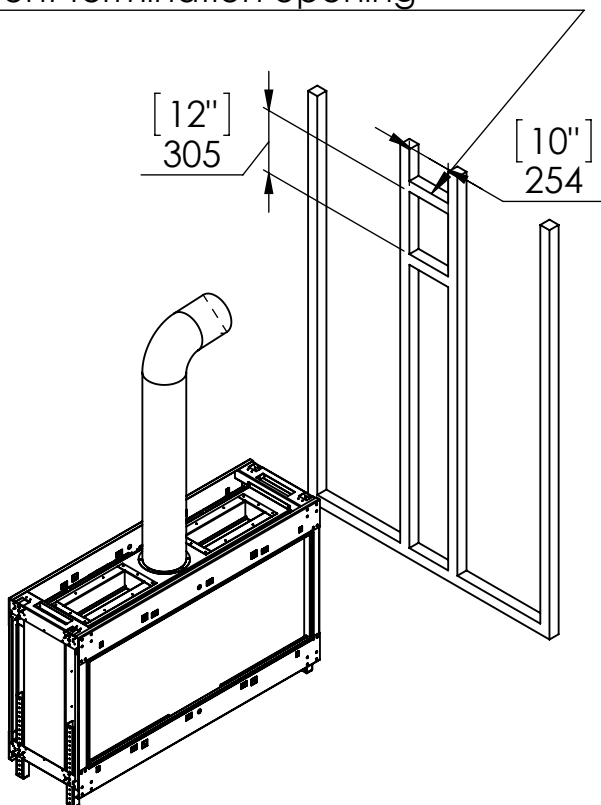

Vertical Termination

For 5 x 8 vent size create 10" x 10" vent termination opening

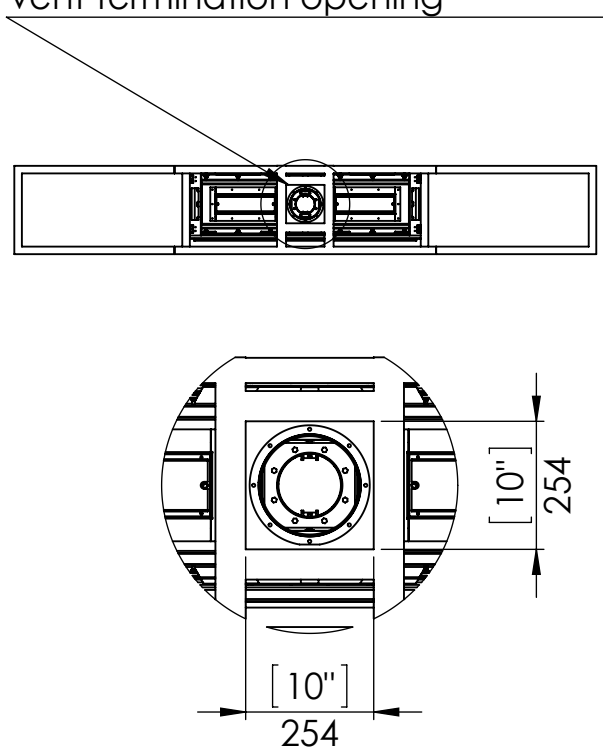

Flat Installation

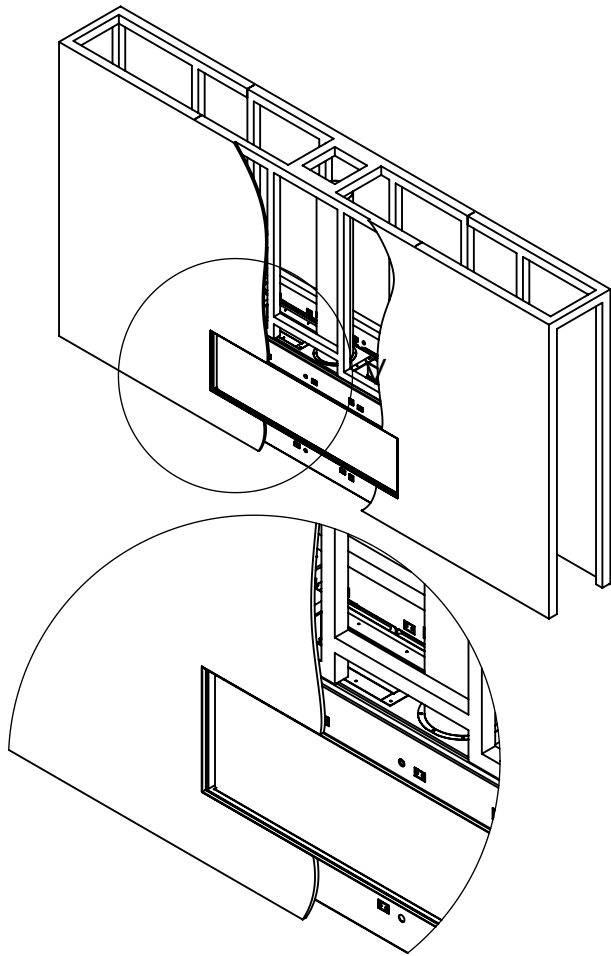

L Shape Installation

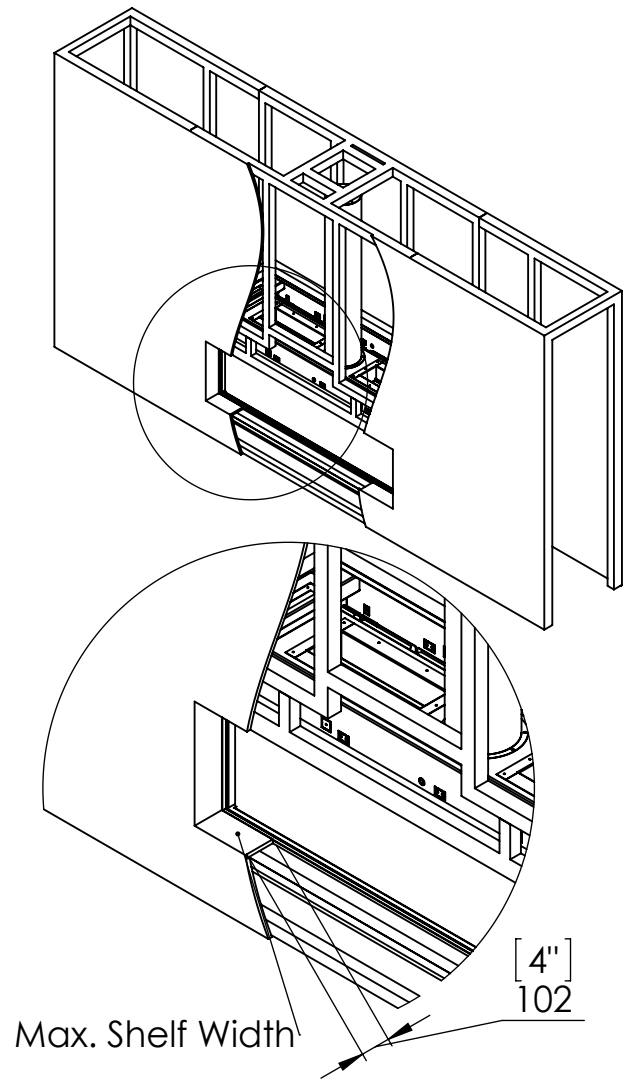

Step 1 - Basic Framing :

Step 1 - Basic Framing :

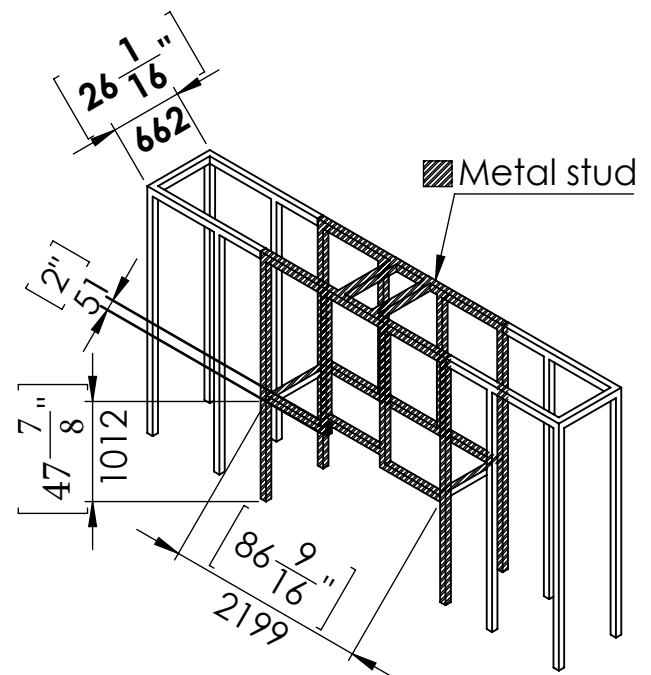
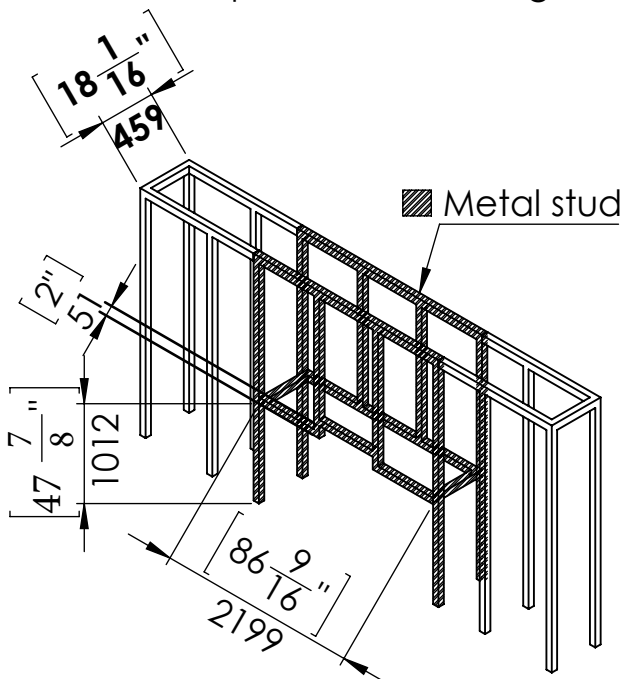

Flat Installation

Step 2 -Positioning the Fireplace:

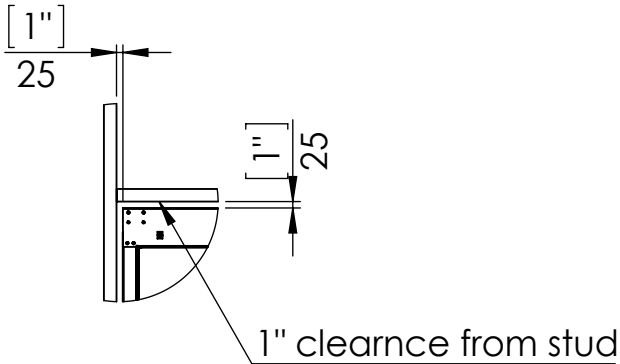
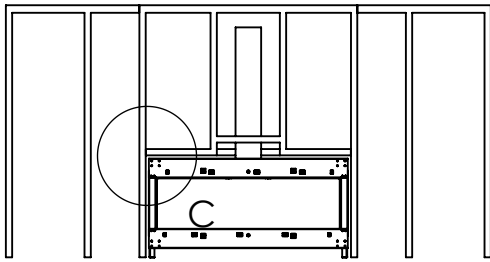
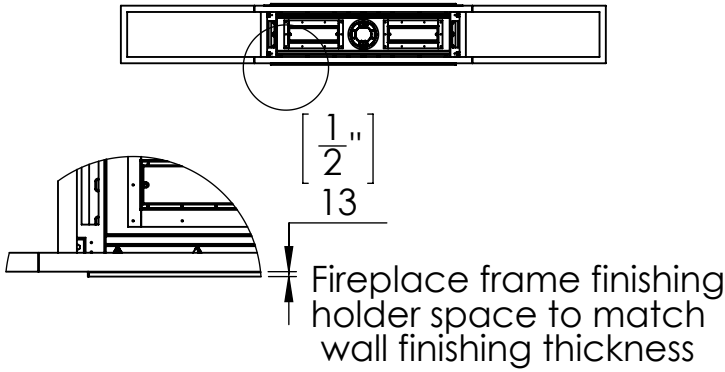

Last Step - Finishing The Fireplace Wall:

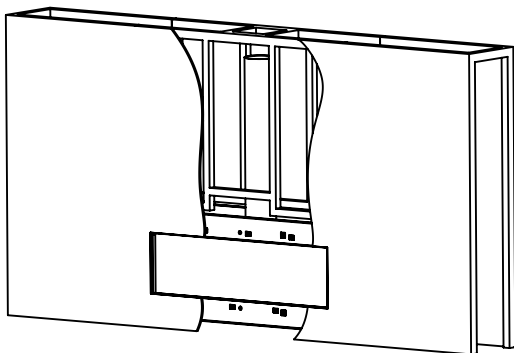

L Shape Installation

Step 2 -Positioning the Fireplace:

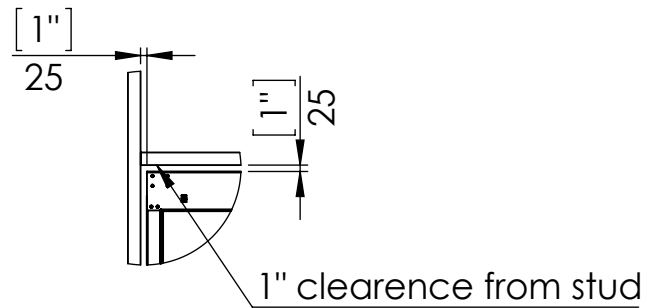
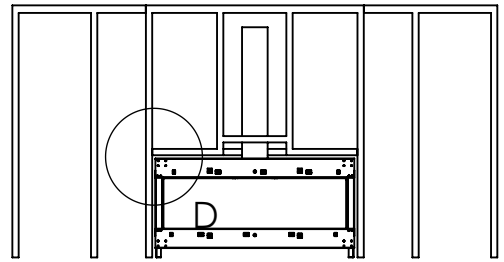
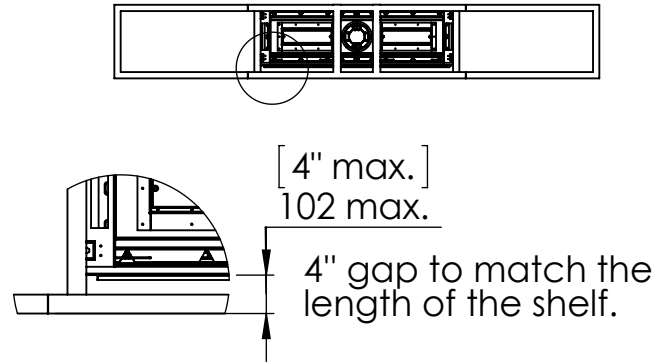

Step 3 - Framing Front Studs For L Shape:

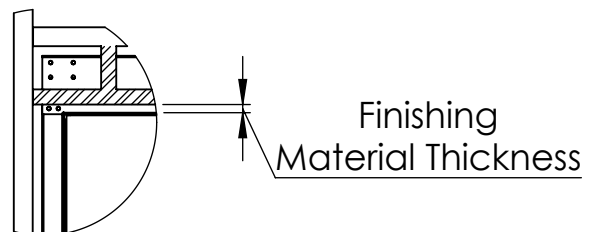
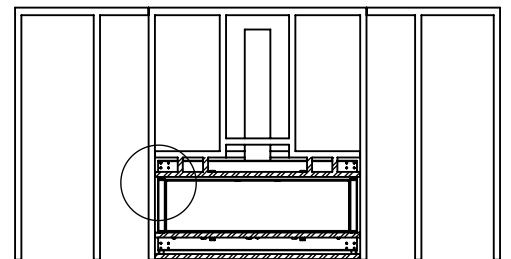

L Shape Finishing Install

Last Step - Finishing The Fireplace Wall:

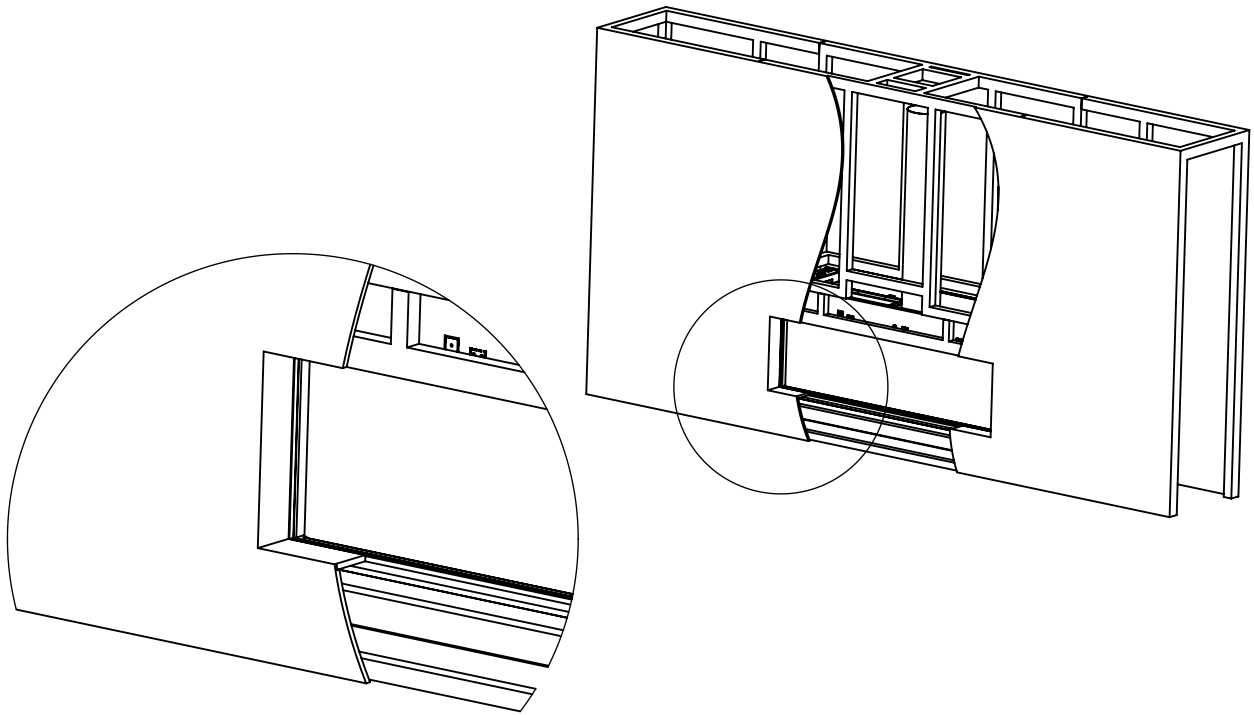

Specifications for Appliance

FLARE SEE THROUGH 80 EH

Factor	NG	LPG
Burner Type	35,105,35	35,105,35
Orifice	500,1200,500	180,380,180
BTU Max.	55700	46000
BTU min.	31000	20750
Kw/h	16.3k	13.5k
Chimney DIA.	5X8	5X8
Manifold Pressure[w.c]	2.6	6.3
Efficiency rate	82	80
Glass Size Length\Width	2020 X 767 mm	79" 8/19 X 30" 3/16
Appliance Weigh	255 kg	563 lb