

Fireplace Dimensions

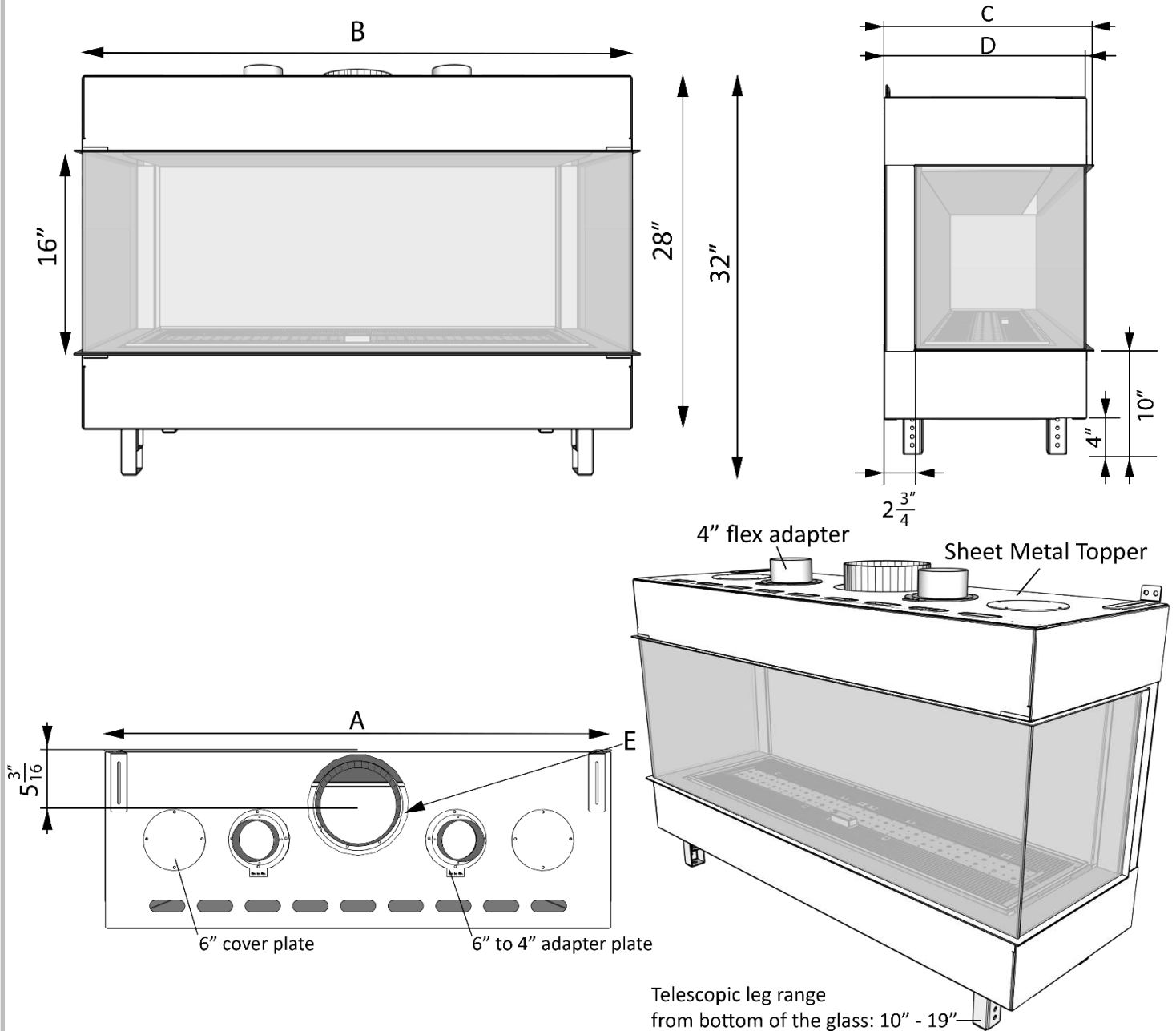

Model		45	50	60	70	80	100
A	IN	43 9/16	50 4/16	60 2/16	69 15/16	82 9/16	99 8/16
	MM	1106	1276	1527	1776	2097	2527
B	IN	43 7/16	50 2/16	59 15/16	69 13/16	82 6/16	99 5/16
	MM	1103	1273	1522	1773	2092	2522
C	IN	18 1/16	18 1/16	18 1/16	18 1/16	18 1/16	18 1/16
	MM	458	458	458	458	458	458
D	IN	17 9/16	17 9/16	17 9/16	17 9/16	17 9/16	17 9/16
	MM	446	446	446	446	446	446
E	IN	4x6	5x8	5x8	5x8	5x8	5x8
	MM	101x152	127x203	127x203	127x203	127x203	127x203

Clearances below are to non-combustible materials.

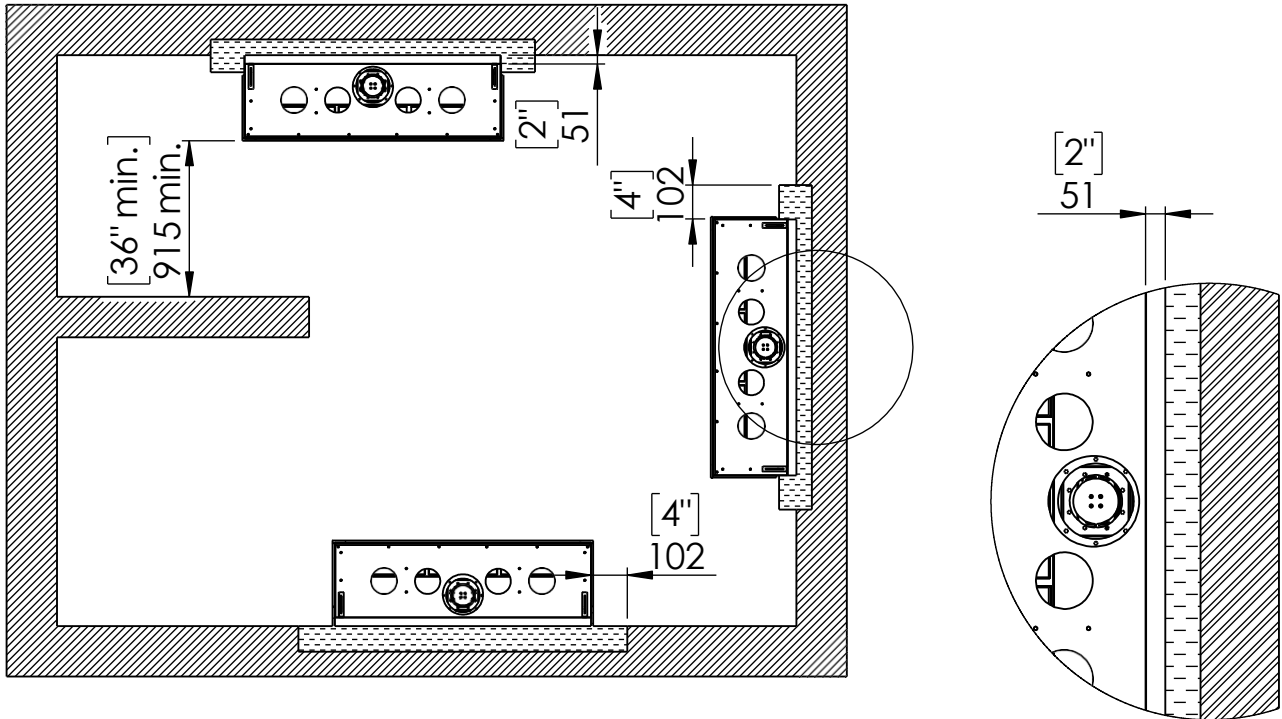

Chimney Installation

Horizontal Termination

For 5x8 vent pipe termination create a 10"x12" opening

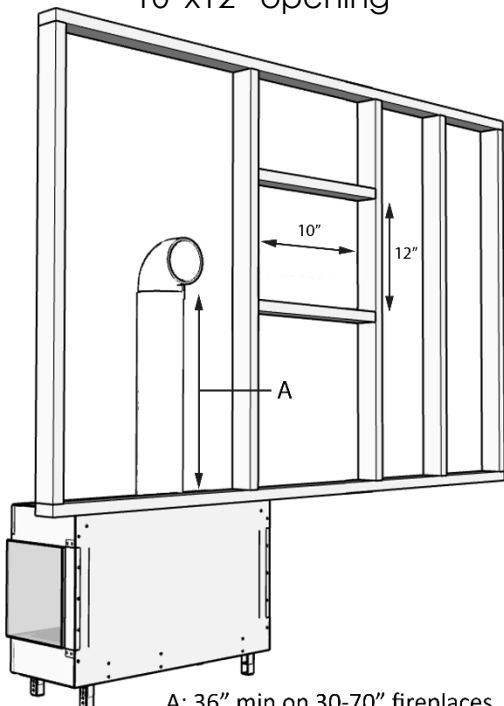

A: 36" min on 30-70" fireplaces
72" min on 80-100" fireplaces

Vertical Termination

For 5x8 vent pipe termination create a 10"x10" opening

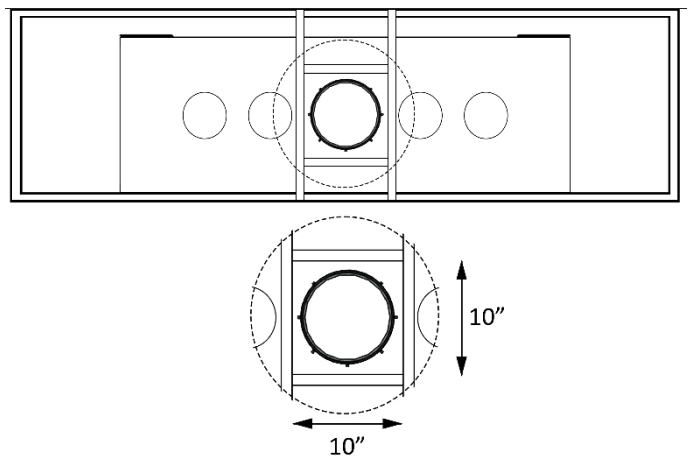

Flat Installation

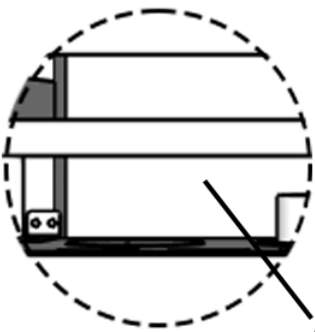
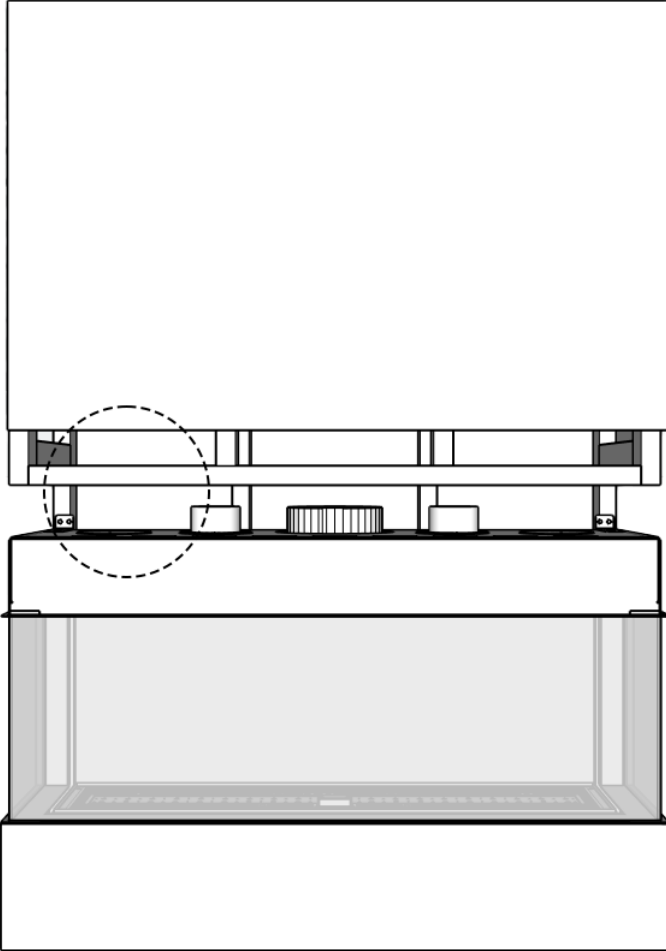

4" clearance to uncovered wood framing above the fireplace.

Recessed Installation

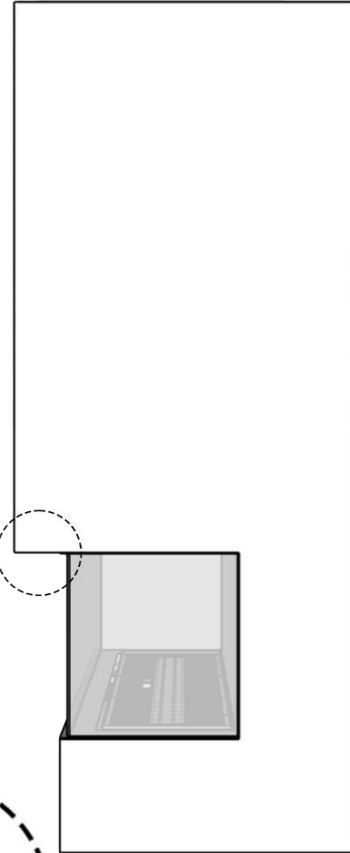

0-4" recommended overhang. 8" max. May be combustible material.

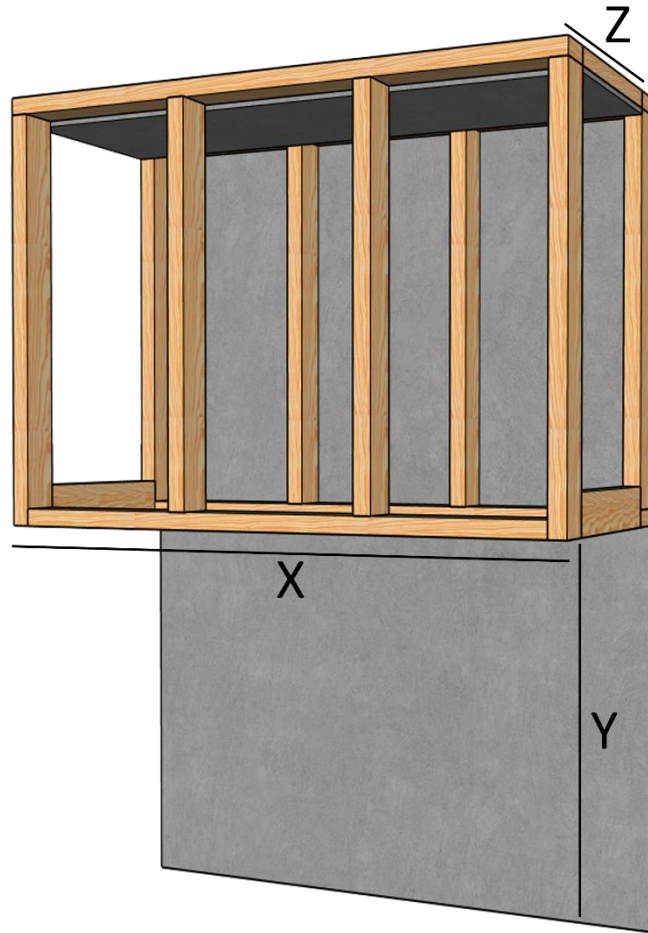

NOTE: Dimension “Y” assumes the fireplace legs are set to the default height of 4”, placing the glass opening at 10” above the floor. This “Y” dimension can change based on where your client wants their viewing window.

*All framing and finishing must be secured to your projects back wall, ceiling or floor and must never bear weight on the fireplace in any circumstance. For more information reference the [Installation Manual](#).

Stud to Stud Framing Around The Fireplace					
Model		X	Y	Z	
				Flat Installation	Recess Installation (4")
45	IN	43 9/16	36	20 9/16	24 9/16
	MM	1106	914	522	623
50	IN	50 4/16	36	20 9/16	24 9/16
	MM	1276	914	522	623
60	IN	60 2/16	36	20 9/16	24 9/16
	MM	1527	914	522	623
70	IN	69 15/16	36	20 9/16	24 9/16
	MM	1776	914	522	623
80	IN	82 9/16	36	20 9/16	24 9/16
	MM	2097	914	522	623
100	IN	99 8/16	36	20 9/16	24 9/16
	MM	2527	914	522	623

Air Intake

Air Intake Louvers			
Flare Model	Part Name	Description	SKU
Flare 30	LUV-50	50 SQ" Louver	LUV50
Flare 45			
Flare 50			
Flare 60	LUV-70	70 SQ" Louver	LUV70
Flare 70			
Flare 80	LUV-100	100 SQ" Louver	LUV100
Flare 100			

**Air intakes are required on Blower Kit and Double Glass equipped fireplaces only.*

***Double the intake on see through and room definers, balancing size and positioning on both long sides.*

****Standardized air intake louvers are available, but designing a unique intake is acceptable.*

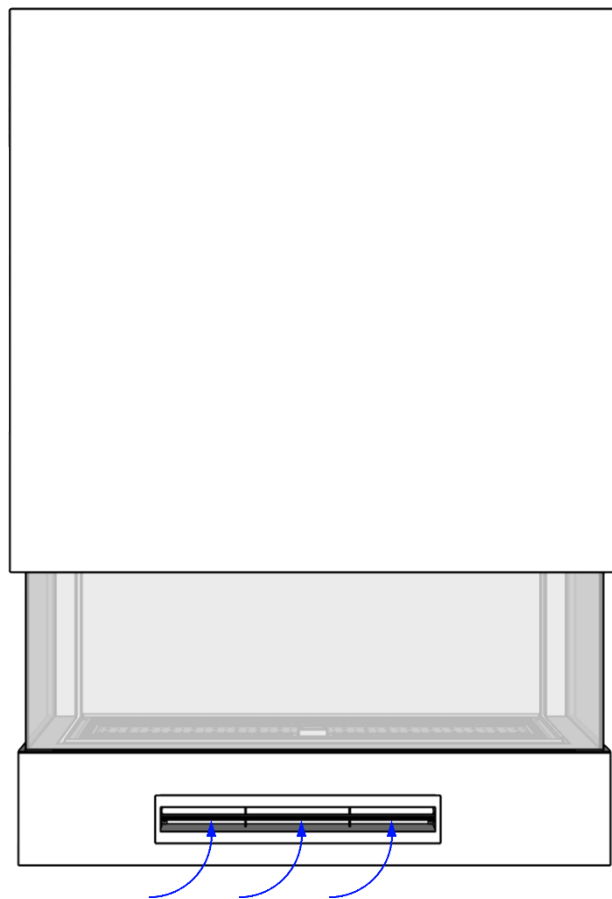

Active Heat Flex Kit

The Passive Heat Flex System Includes:

- Active heat flex fan(s)
- 4" flex pipe adapters
- Active heat flex cover and sides
- 6" cover plates
- 4" – 6" cover plates

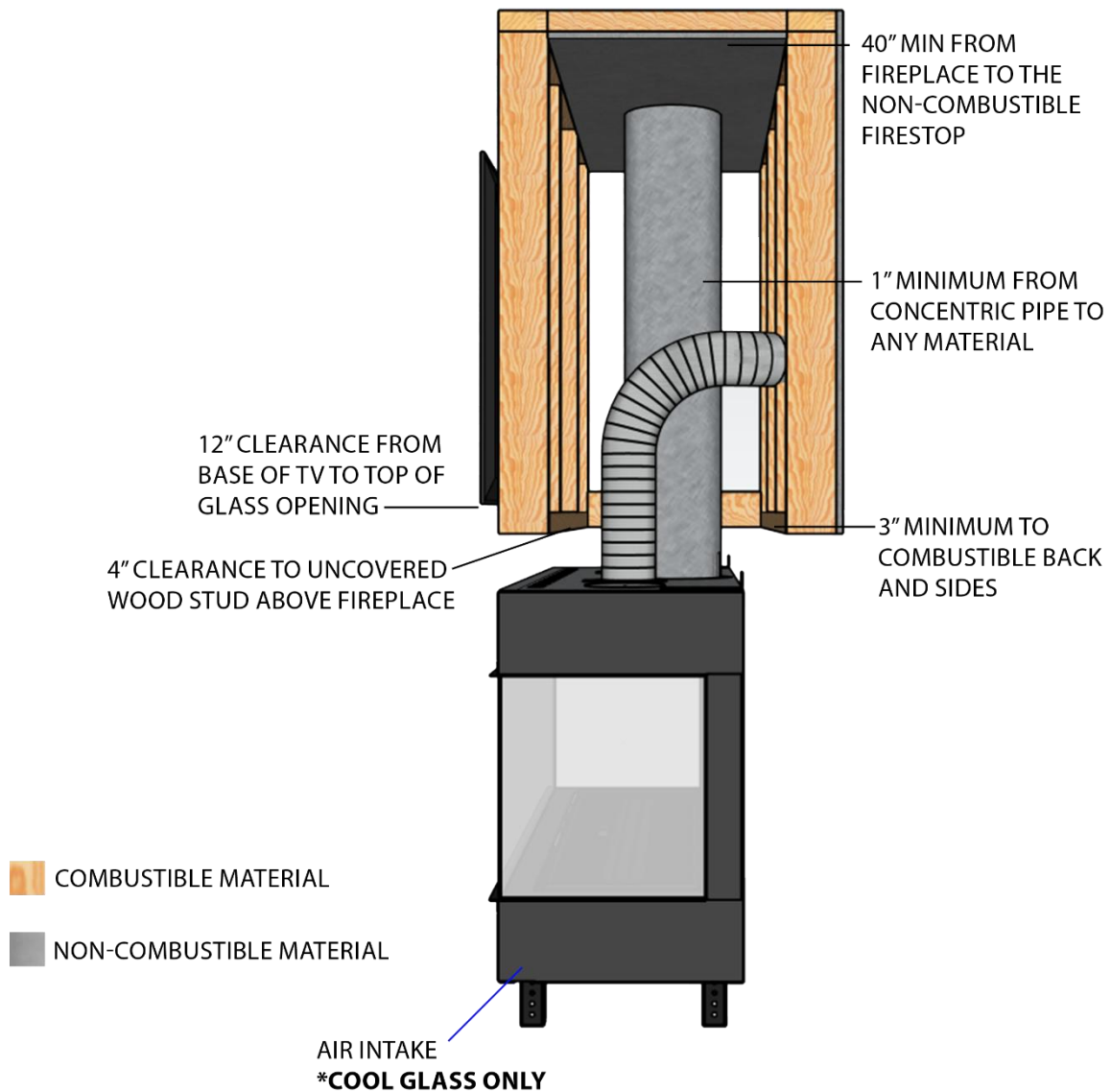

Wood Framing Clearances and Materials Example

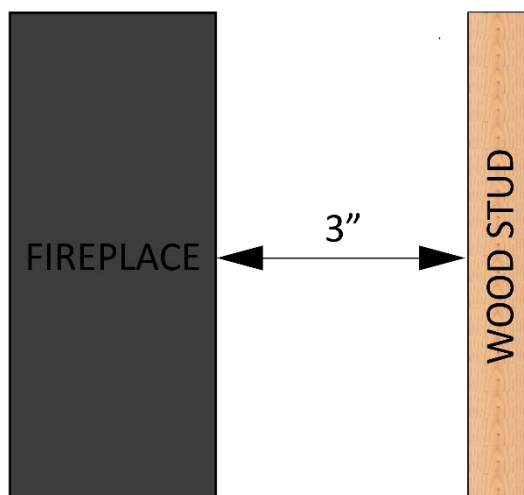

*Any combustible material found within the fireplace cavity must maintain a 3" clearance to the sides and back, and a 4" clearance to the top of the fireplace.